



NORDEN MFG

Owner's Manual

AF8 Hay Accumulator



MADE IN THE USA 

Read, Understand, and Follow the manual. This manual provides information and procedures to safely operate and maintain the Hay Accumulator.



CONTENTS

1. INTRODUCTION	4	7. OPERATION	25
1.1 Intended Usage	4	7.1 Operating Safety	25
1.2 Operator Orientation	4	7.2 Pre-Operation Checklist	25
1.3 Specifications	4	7.3 Attaching to Baler	25
1.4 Serial Number Location	4	7.3.1.. Break In	26
1.5 Owner/Operator Manual Storage	5	7.3.2.. Stuck Bale Removal	26
1.6 Product Improvements	5	7.4 Operating Procedures	26
1.7 Disposal of Equipment at End of Useful Life ...	5	7.4.1.. Cornering	26
1.8 Unanswered Questions	5	7.4.2.. Hillside	26
2. SAFETY	6	7.4.3.. High Moisture Hay	26
2.1 General	6	7.5 Detaching From Baler	26
2.2 Safety Alert Symbol	6	8. TROUBLESHOOTING	28
2.3 Safety Icons Nomenclature	7	8.1 Front Gate Bounces in Home Position	28
2.3.1.. Personal Protection/Important		8.2 Front Gate Bounces in Open Position	28
Information	7	8.3 Back Gate Trip Adjustments	29
2.3.2.. Prohibited Actions	7	9. TRANSPORTING	30
2.3.3.. Hazard Avoidance	7	9.1 General Safety	30
2.4 General Operating Safety	8	9.2 Safety Chain	30
2.5 Safety Signs	8	9.3 Highway and Transport Operations	30
2.6 Practice Safe Maintenance	8	9.3.1.. Setting the Hitch for Transport	31
2.7 Training	8	9.3.2.. Lights	31
2.8 Sign-Off Form	9	9.4 Pre-towing Checklist	31
3. SAFETY SIGNS AND LABELS	10	10. STORAGE	32
3.1 General Information	10	10.1 .. Placing in Storage	32
3.2 Contact Information	10	10.2 .. Removing from Storage	32
3.3 How to Install Replacement Safety Signs	10	11. MAINTENANCE	33
3.4 Safety Sign Locations	11	11.1 .. General Information	33
3.5 Hay Unit Safety Signs	12	11.2 .. Maintenance Safety	33
4. NAMES OF MAJOR PARTS	13	11.3 .. Pre Maintenance Instructions	34
4.1 Undercarriage	14	11.4 .. Lubrication	34
4.2 Unit Bed and Chute	14	11.5 .. Wheel Bearing Adjustment	35
4.3 Linkage System	14	11.6 .. Swivel Dolly Bushings	35
4.4 Belted Base Chute	14	11.7 .. Tire Safety	36
4.5 Lights	14	11.8 .. Tire Inflation	36
4.6 Linkage System Operation	15	11.9 .. Bolt Torque Requirements	36
5. ASSEMBLY	17	11.10 Standard Torque Values	36
6. SET-UP	19	11.11 Welding Repairs	36
6.1 Tractor Requirements	19	11.12 Service Record	37
6.1.1.. Equipment and Capabilities	20	12. PARTS SECTION	38
6.2 Tractor Safety Devices	20	12.1 .. Ordering Parts	38
6.3 Chamber Extension Assembly	20	12.2 .. Contact Information	38
6.4 Baler-Accumulator Hook Up	20	12.3 .. Decals	38
6.5 Baler Chamber Tension Settings	24	12.4 .. Hay Accumulator Undercarriage	39
6.6 Baler Hitch Special Requirements	24	12.5 .. Hub Assembly	40
6.6.1.. New Holland® (NH) Balers	24	12.6 .. Accumulator Bed and Chute	41
6.6.2.. John Deere® (JD) Balers	24	12.7 .. Linkage System	42
6.6.3.. Massey 1840 Hitch Spacers	24	12.8 .. Belt and Tensioner	44
6.6.4.. In-line Balers	24	12.9 .. Bale Chamber Extension	45
		12.10 Bale Roller	46
		12.11 Lighting	47
		12.12 Spring Kit	48

1. Introduction

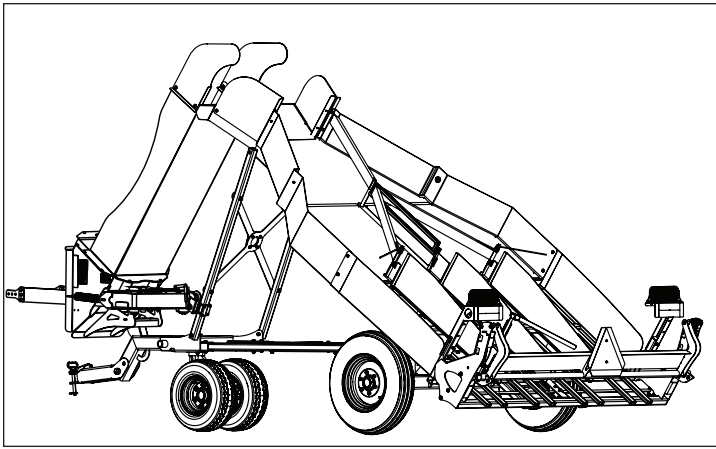

Using no hydraulics or electronics, the Norden Hay Accumulator automatically arranges bales into groups that can then be picked up with a Grabber mounted on a loader. Handling multiple bales of hay at one time allows wagons to be loaded more quickly, as well as quicker stacking in the barn.

Please read the manual carefully to become familiar with your new Norden Hay Accumulator. This manual has been developed through our experience with the equipment and feedback from our customers. Ultimately it is our desire that you will be operating your hay unit as a seasoned professional in no time!

1.1 Intended Usage

Do not use this unit for any other purpose than its intended use of arranging bales into groups that can then be picked up with Grabbers.

1.2 Operator Orientation

The directions left, right, front, and rear, as mentioned throughout this manual, are as seen from the tractor operator's seat and facing in the direction of travel.

Note: The specific term "hay accumulator" will be referred to simply as "unit" throughout the rest of this manual.

1.3 Specifications

Overall Width	7' 10"
Overall Length	17' 0"
Overall Height	9' 2"
Overall Weight	1970 lbs.
Bale Capacity	8
Bale Size	14 x 18" or 16 x 18", 32 to 48" long
Tires	9.5L-15SL (Rear) 20.5 x 8-10 (Front)

Specifications subject to change without notice.

1.4 Serial Number Location

The unit's serial number is located near the front of the unit bed (see arrow). Please use this number when requesting service, seeking information, or ordering parts. Record the serial number in the space provided for easy reference when contacting Norden Mfg LLC with questions.

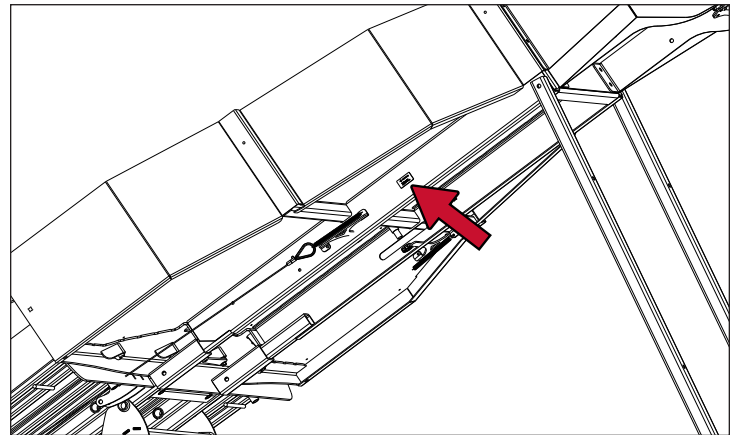

Serial Number _____

Date of Purchase _____

1.5 Owner/Operator Manual Storage

Store the Owner/Operator manual and other operating materials in the document storage tube, located under the unit bed.

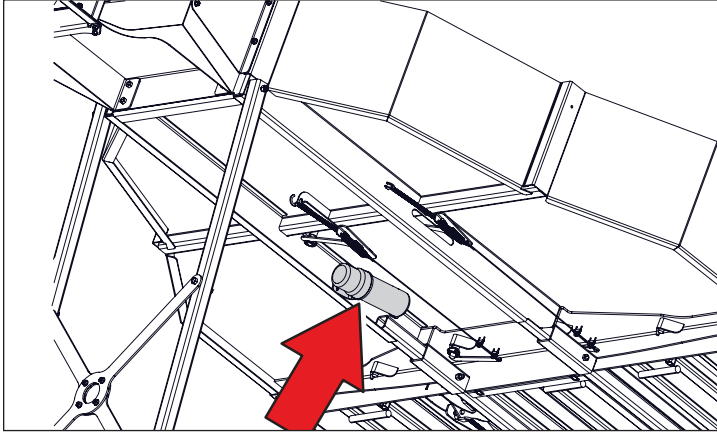

1.6 Product Improvements

Because Norden Mfg LLC maintains an ongoing program of product improvement, we reserve the right to make improvements in design or changes in specifications without incurring any obligation to install them on units previously sold.

1.7 Disposal of Equipment at End of Useful Life

The Norden Mfg LLC Hay unit has been designed for the specific purpose of arranging bales into groups. When this unit is no longer capable of performing its intended use, it should be dismantled and scrapped. Do not use any materials or components from this unit for any other purpose.

1.8 Unanswered Questions

If you have any questions not answered in this manual, require additional copies, or the manual is damaged, please contact your dealer, or:

Norden Mfg LLC
4210 Kinsman Road NW
North Bloomfield, OH 44450

Phone: 877-296-5851
Fax: 440-693-4336
E-mail: parts@nordenmfg.com

The manual is also available for download at:
www.nordenmfg.com

2. Safety

2.1 General

Most work related accidents are caused by failure to observe basic safety rules or precautions. An accident can often be avoided by recognizing potentially hazardous situations before an accident occurs. As you operate and maintain the unit, you must be alert to potential hazards. You should also have the necessary training, skills, and tools to perform any assembly procedure.

Improper operation and/or maintenance of this unit could cause a dangerous situation that results in injury or death.

Do not use this unit until you read and understand the information contained in this manual. Do not use the Norden Hay Unit for anything other than its intended purpose.

WARNING

 Do not use the unit until you read and understand the information contained in this manual and all related equipment manuals.

 Safety precautions and warnings are provided in this manual and on the unit. If these hazard warnings are not heeded, bodily injury or death could occur to you or to other persons.

Norden Mfg LLC cannot anticipate every possible circumstance that might involve a potential hazard. The warnings in this manual and on the product are, therefore, not all-inclusive. If a method of operation not specifically recommended by us is used, you must satisfy yourself that it is safe for you and for others. You should also ensure that the unit will not be damaged or be made unsafe by the methods that you choose.

The information, specifications, and illustrations in this manual are based on the information that was available at the time this material was written and can change at any time.

2.2 Safety Alert Symbol

 This is the safety alert symbol. It is used to alert you to potential personal injury hazards. Obey all safety messages that follow this symbol to avoid possible injury or death.

This manual contains WARNINGS, CAUTIONS, NOTICES, SAFETY INSTRUCTIONS, and NOTES which must be followed to prevent the possibility of improper service, damage to the equipment, personal injury, or death. The following key words call the reader's attention to potential hazards.

Hazards are identified by the "Safety Alert Symbol" and followed by a signal word such as "WARNING" or "CAUTION".

WARNING

Indicates a potentially hazardous situation which, if not avoided, could result in death or serious injury.

CAUTION

Indicates a potentially hazardous situation which, if not avoided, may result in minor or moderate injury.

NOTICE

Indicates that equipment or property damage can result if instructions are not followed.

SAFETY INSTRUCTIONS













Safety instructions (or equivalent) signs indicate specific safety-related instructions or procedures.

NOTE: Contains additional information important to a procedure.

2.3 Safety Icons Nomenclature

This manual and the equipment has numerous safety icons. These safety icons provide important operating instructions which alert you to potential personal injury hazards.

2.3.1 Personal Protection/ Important Information

-  Read the manual
-  Eye protection
-  Hearing protection
-  Hand protection
-  Foot protection
-  First aid kit
-  Fire extinguisher
-  Inspect equipment
-  Use proper tools
-  Use support stands
-  Weight rating
-  Use OEM parts
-  Use ROPS and seat belt
-  Maintain safety signs
-  Place in park

 Remove key

 Stop engine

 Visibility

 Set parking brake

2.3.2 Prohibited Actions

 Do not alter or modify

 Do not weld

 No riders

 No children

 No alcohol

 No drugs

2.3.3 Hazard Avoidance

 Crushing hazard

 Crushing hazard

 Slipping hazard

 Tripping hazard

 Falling hazard

 Fire hazard

 Safety alert symbol

 Maintain tire pressure

 Defective or broken part

 Chock wheels

 Maintain safe distance

 Pinch point hazard

 Overturn hazard

 Negative tongue weight hazard

 Rollover hazard

2.4 General Operating Safety

WARNING

Failure to follow these safety instructions could result in death or serious injury.



Read, Understand, and Follow the Manual
To prevent personal injury or even death, be sure you read and understand all of the instructions in this manual and other related OEM equipment manuals! This unit was designed for a specific application; **DO NOT** modify or use this unit for any application other than that for which it was designed. Units operated improperly or by untrained personnel can be dangerous! Inexperienced operators should receive instruction from someone familiar with the equipment before being allowed to operate the unit.



Do Not Operate

Do not use the unit if it is in need of repair. If you believe the unit has a defect which could cause injury or death, you should immediately stop using the unit.



Fall Hazard

Do not use the unit as a platform. Do not climb on the unit. Do not stand on the unit at any time. Do not ride on the unit or allow others to ride on it.



Pinch Point Hazard

Keep hands and feet away from any moving parts to prevent injury.



Impaired User Hazard

Do not attempt to assemble, operate, or maintain the unit under the influence of drugs or alcohol. Consult your doctor before using the unit while taking prescription medications.



Falling Hazard

Do not allow riders on the tractor or unit at any time. Falling could result in severe injuries or death.



Stay Clear

Clear the area of people, especially small children, before using the unit. Under no circumstances should young children be allowed to work with or around the unit.

2.5 Safety Signs

CAUTION



Legible Safety Signs

Keep safety signs clean and legible at all times. Replace any safety sign or instruction sign that is missing or not legible. Refer to the Safety Sign Location section for additional information

When replacing parts that displayed a safety sign, replace the safety sign as well.

Replacement safety signs (labels) are available from your authorized Dealer Parts Department or the factory at no cost.

2.6 Practice Safe Maintenance

SAFETY INSTRUCTIONS



Understand service procedures before doing any work. Keep the work area clean and dry.



Keep all parts in good working condition and properly installed. Replace worn or broken parts immediately.



Do not modify the unit or its safety devices. Do not weld on the unit. Unauthorized modifications may impair its function and safety.

2.7 Training

Anyone who will be using and/or maintaining the unit must read, clearly understand, and follow ALL safety, operation, and maintenance information presented in this manual, accessory or tractor manuals, and the safety signs.

If you do not understand any information in this manual, see your dealer or contact Norden Mfg LLC before proceeding.

Do not use or allow anyone else to use this Hay Unit until all information has been reviewed. Annually review this manual before the season start-up.

Make periodic reviews of SAFETY and OPERATION a standard practice. An untrained operator is not qualified to use this unit.

3. SAFETY SIGNS AND LABELS

3.1 General Information

The types of safety signs (hazard labels) and instructional labels, along with their locations on the equipment, are shown in the following illustrations. Good safety practices require that you familiarize yourself with the various safety signs, the type of warning, and the area or particular operation related to that area that requires your SAFETY AWARENESS.



Think SAFETY!

Work SAFELY!

Pay close attention to the safety signs and instructional labels attached to the tractor, baler, and hay unit. The safety signs attached to the unit are reproduced in this section. If the unit is missing a label or one is unreadable, replace the label before using it.

SAFETY INSTRUCTIONS



Safety Signs and Instructional Labels

Keep safety signs or instructional labels clean and legible at all times. Use a clean, damp cloth to clean safety decals.

Replace any missing or hard-to-read safety signs or instructional labels.

Use care when washing or cleaning the equipment. Make sure not to remove or damage the labels. When using a pressure washer to clean the unit, avoid spraying too close to decals; high-pressure water can enter through very small scratches or under edges of decals causing them to peel or come off.

Locations for the labels and replacement part numbers are shown in this section.

Replacement parts must have replacement labels attached before the unit is used.

Labels are available from your authorized dealer or from Norden Mfg LLC at no charge.

3.2 Contact Information

For replacement decals, contact:

Norden Mfg LLC
4210 Kinsman Road NW
North Bloomfield, OH 44450

Phone: 877-296-5851
Fax: 440-693-4336
E-mail: parts@nordenmfg.com

3.3 How to Install Replacement Safety Signs

Clean and dry the installation area.

NOTE: Do not install the signs if the temperature is below 50°F.

Determine the exact position before you remove the backing paper.

Remove the backing paper.

Align the sign over the specified area and carefully press the sign to the part/frame.

NOTE: Small air pockets can be pierced with a pin and smoothed out using the piece of backing paper.

3.4 Safety Sign Locations

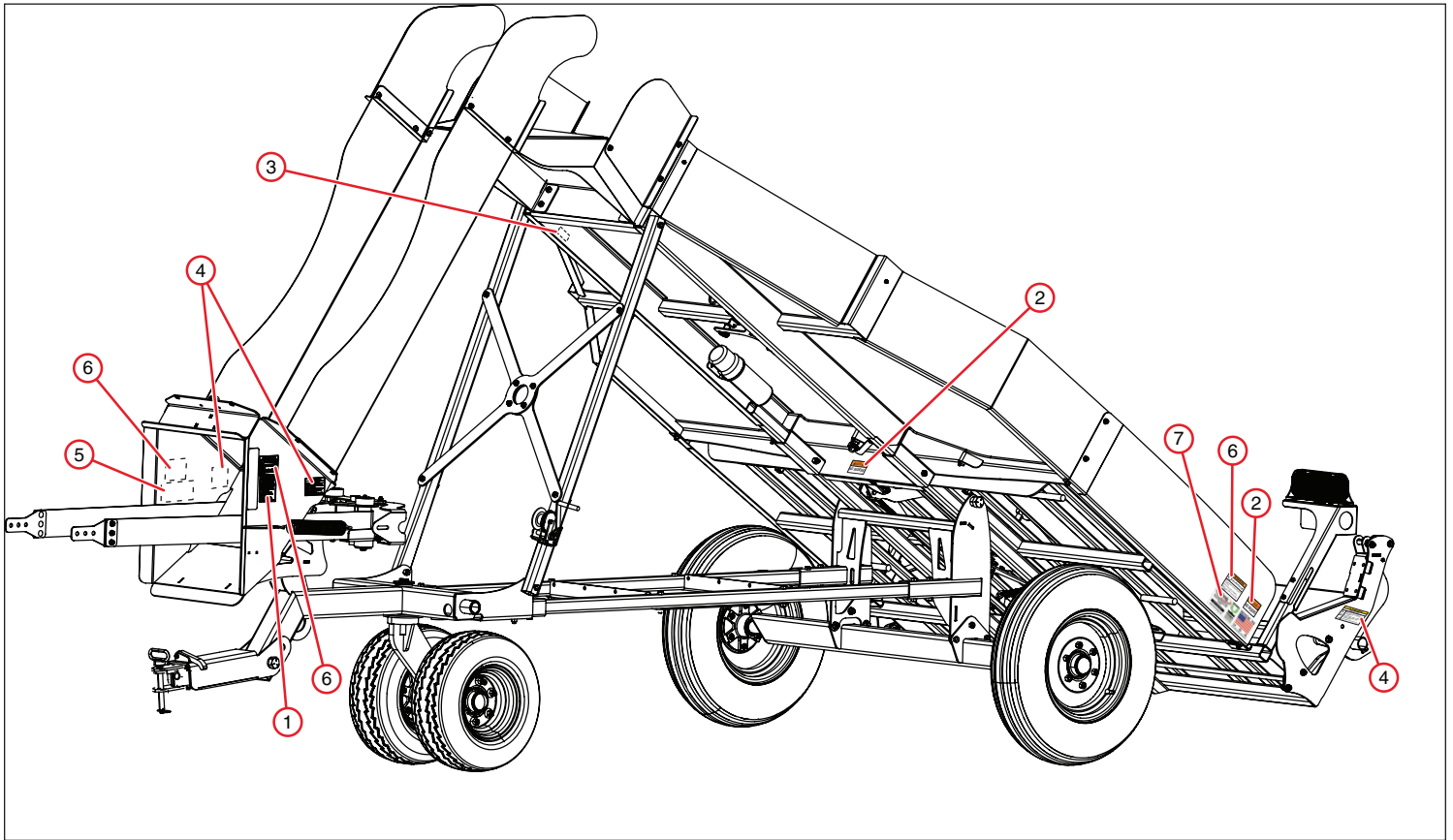

Item	Type	Description	Qty.
1	WARNING	Read the Manual	1
2	WARNING	No Riders	3
3	INFORMATIONAL	Serial Number	1
4	WARNING	Pinch Point	4
5	WARNING	Do Not Transport at Speeds Over 20 MPH	1
6	WARNING	Fall Hazard	4
7	INFORMATIONAL	Made in USA	1

3.5 Hay Unit Safety Signs

1. WARNING—Read Manual

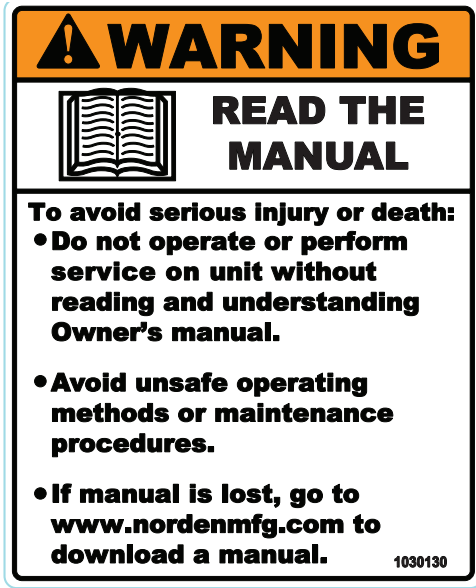

2. WARNING—No Riders



3. INFORMATIONAL—Serial Number



4. CAUTION—Pinch Point

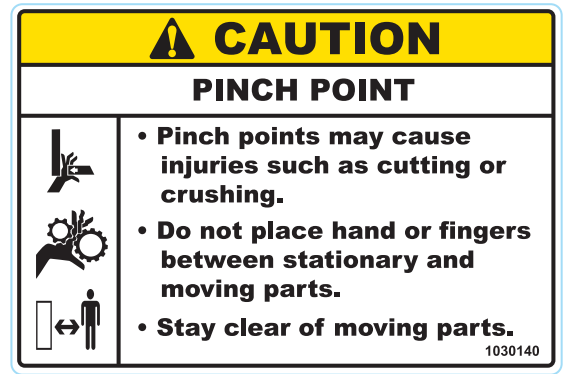

5. WARNING—Transporting

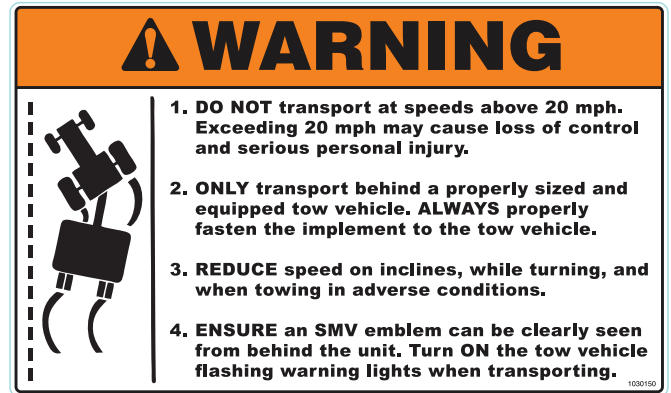

6. WARNING—Falling Hazard



7. INFORMATIONAL—Manufacture Placard

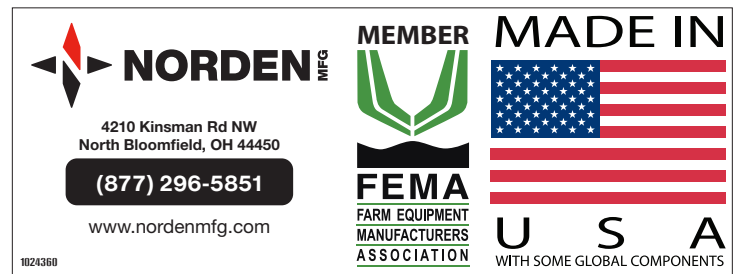

4. Names of Major Parts

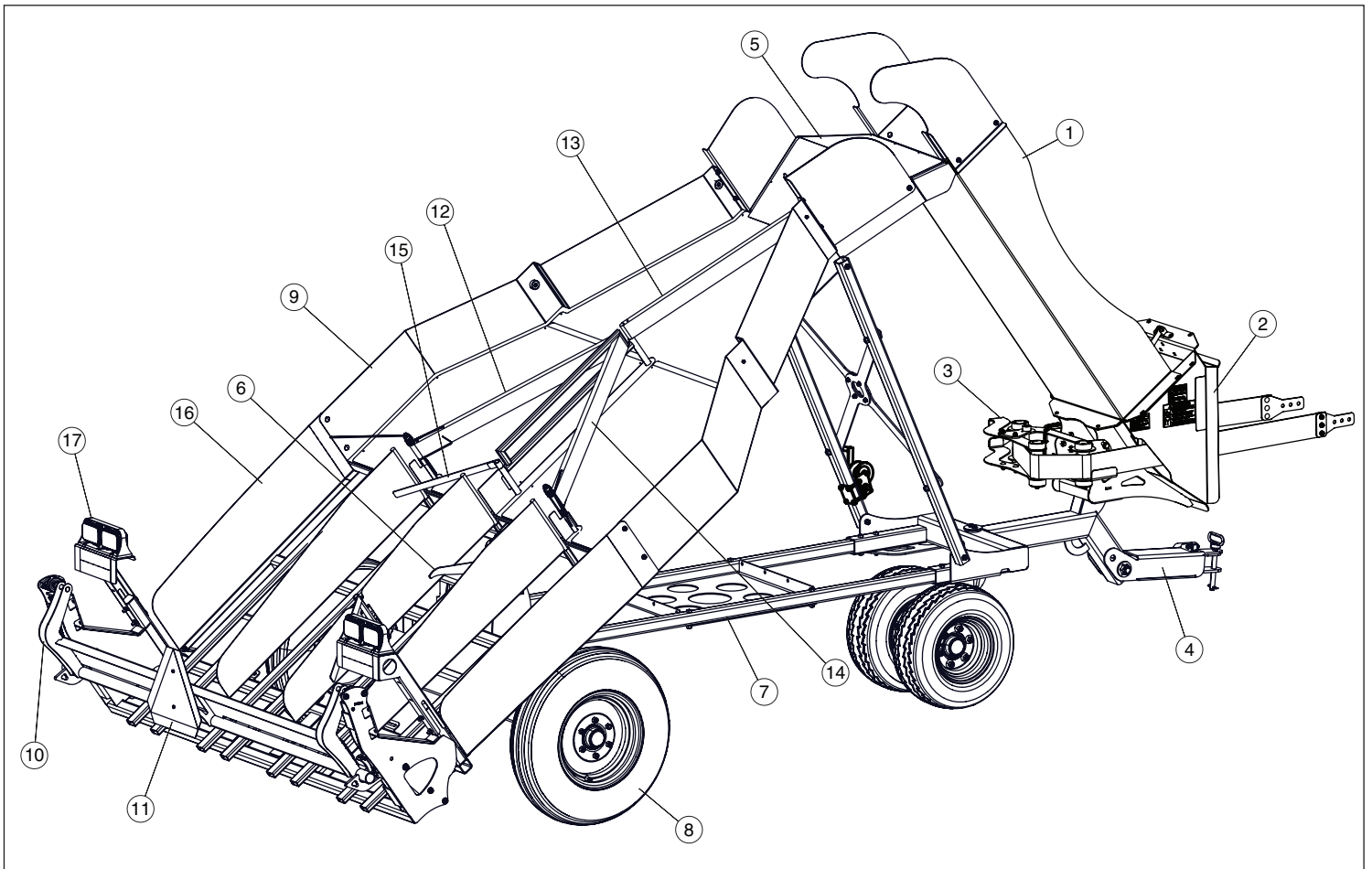

Item	Description
1	Main Chute
2	Belted Base Chute
3	Belt Tensioner
4	Hitch
5	Chute Platform
6	Back Gate Trip Flipper
7	Reach Pole
8	Rear Tires, 9.5L-15SL
9	Accumulator Bed

Item	Description
10	Back Gate
11	Slow Moving Vehicle Sign
12	Gate #1
13	Gate #2
14	Gate #3
15	Gate Switch
16	Side Panels
17	Tail Lights

4.1 Undercarriage

The undercarriage supports the overall unit and includes the axles, wheel assemblies, swivel dolly, base chute, and the hitch.

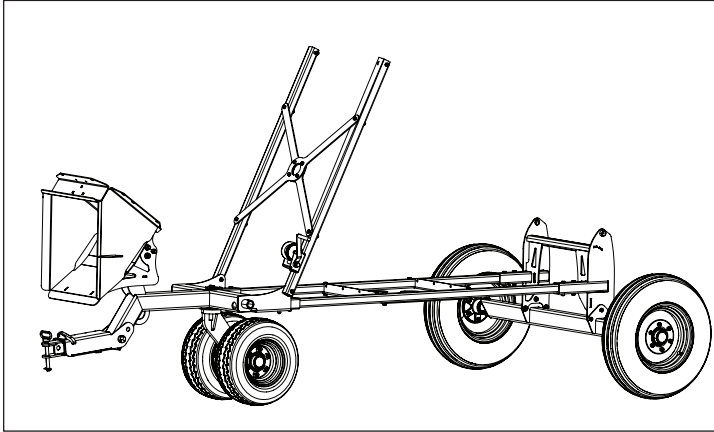

4.2 Unit Bed and Chute

The bed guides and positions the bales on the unit. The bed rests on the frame and is secured at the rear of the frame with two heavy duty hinges. Shipped in the resting position, at assembly the bed is raised into position and permanently secured.

The twisted chute rotates the bales 90° as they pass through it, so that they enter the bed on edge.

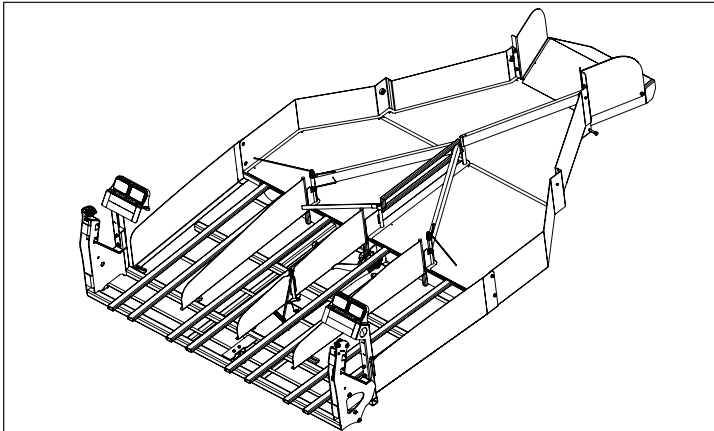

4.3 Linkage System

The linkage system directs the bales through the bed. The system consists of four gates, two gate switches, a back gate, a trip mechanism, and a network of cables and springs.

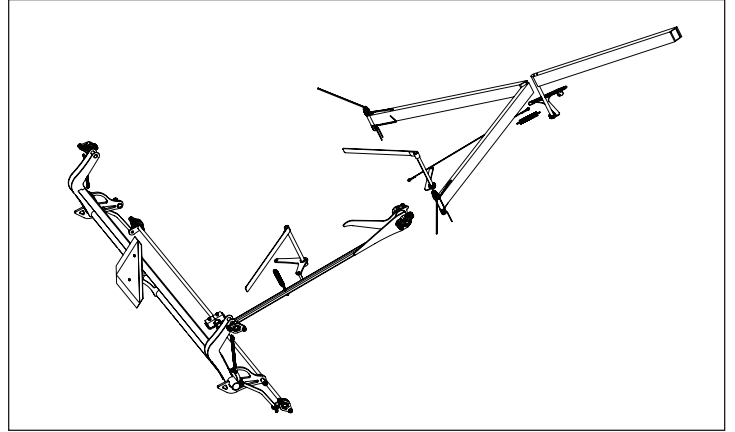

4.4 Belted Base Chute

The belted base chute is standard equipment on the unit and will aid in cornering.

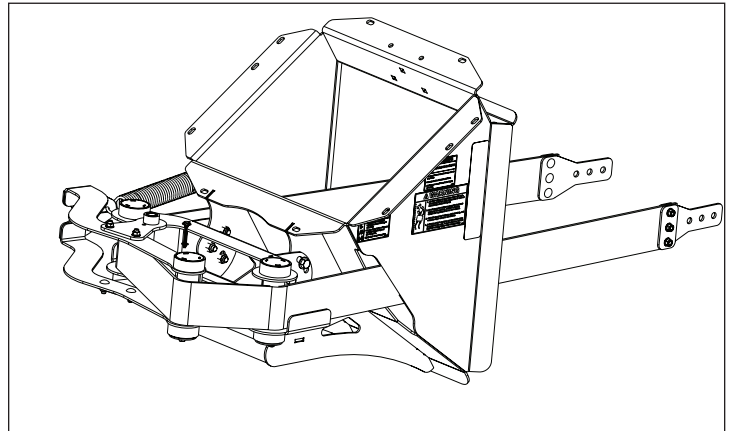

4.5 Lights

The unit is equipped with agricultural lights and an enhanced flasher lighting module to meet ASABE S279 standard.

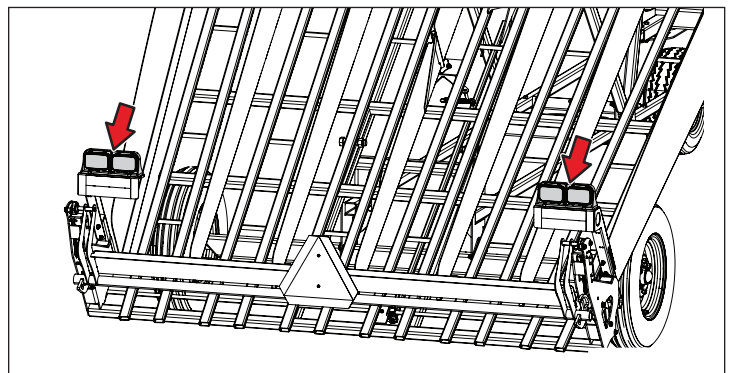

4.6 Linkage System Operation

1. Bale #1 enters the unit and slides downward and into position.

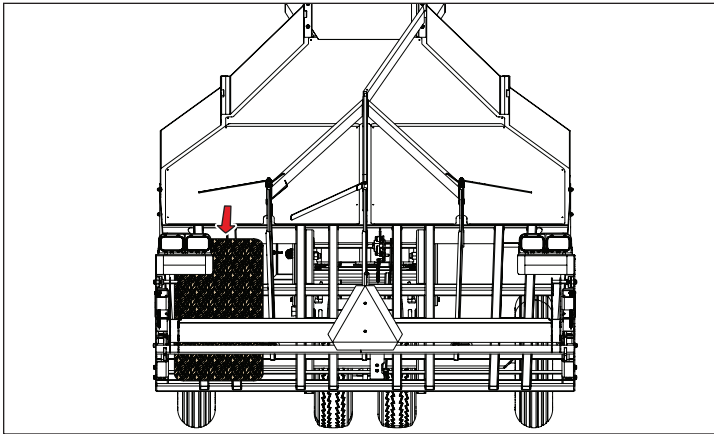

2. Bale #2 enters the unit and slides downward and into position, rotating the gate actuating spring and shifting gate #1 to open row #2.

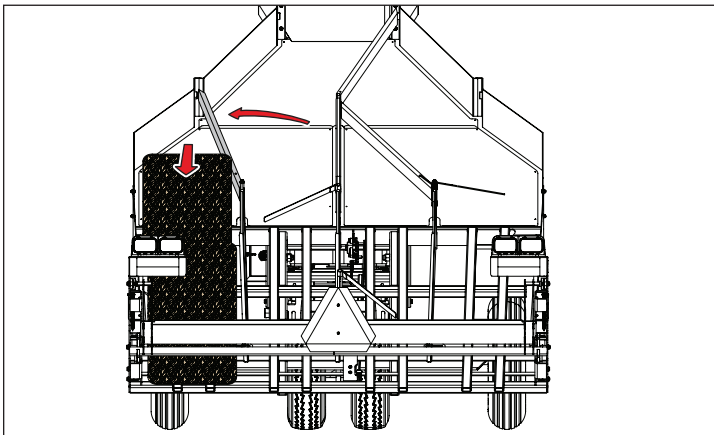

3. Bale #3 enters the unit and slides downward and into position.

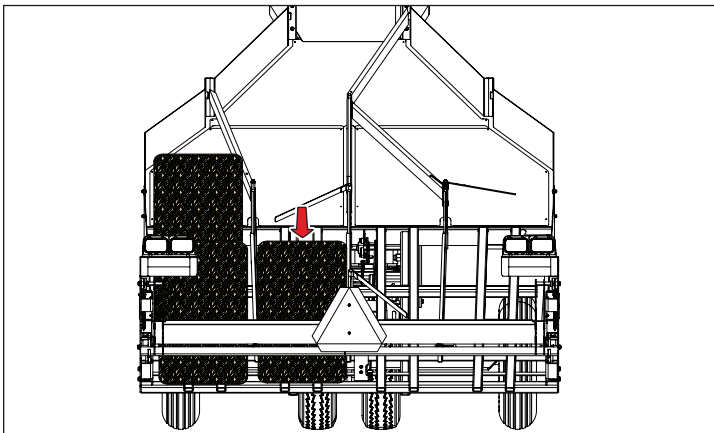

4. Bale #4 enters the unit and slides downward and into position, rotating the gate actuating spring and shifting gate #2 to open row #3.

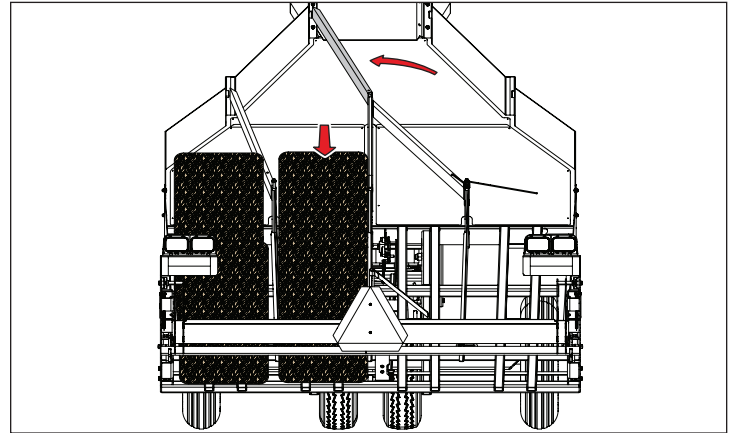

5. Bale #5 enters the unit and slides downward and into position.

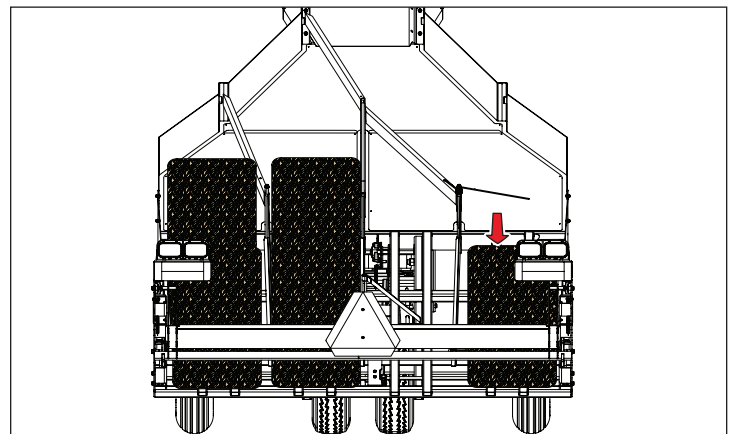

6. Bale #6 enters the unit and slides downward and into position, rotating the gate actuating spring and shifting gate #3 to open row #4.

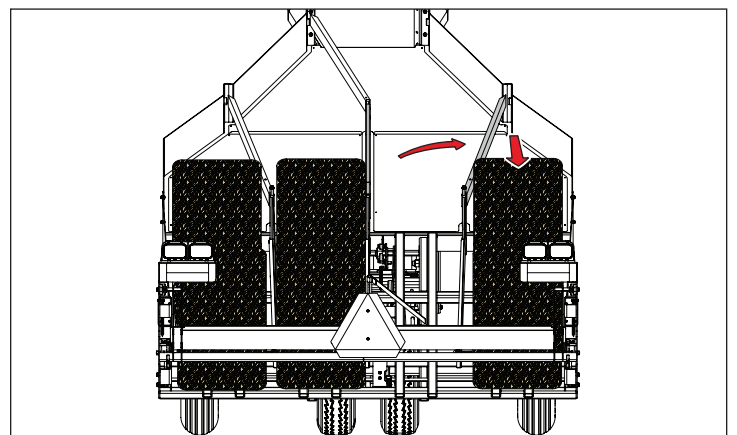

7. Bale #7 enters the unit and slides downward and into position, rotating the back gate trip slider to engage the trip flipper.

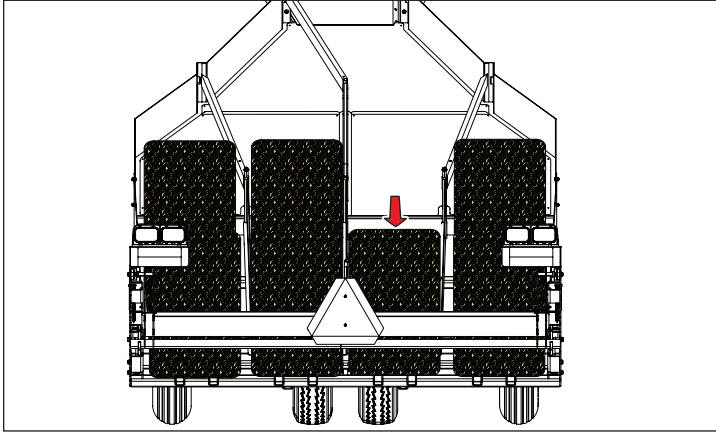

8. Bale #8 enters the unit and slides downward, depressing the back gate trip flipper to open the back gate.

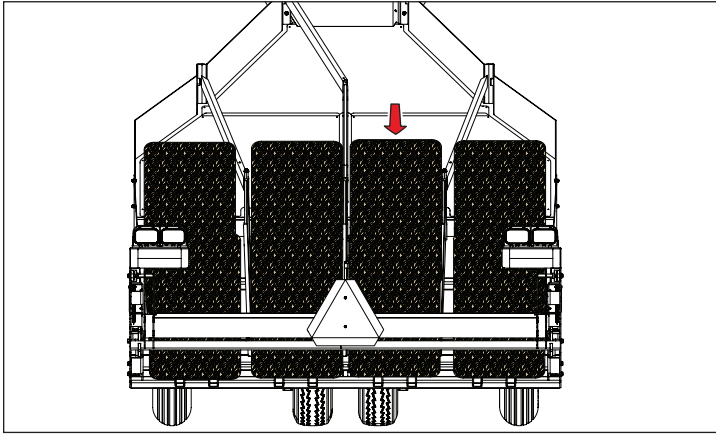

9. Once the back gate is open, the bales slide to the ground. When all bales are clear, the back gate returns to its original position and latches. All gates return to their original position.

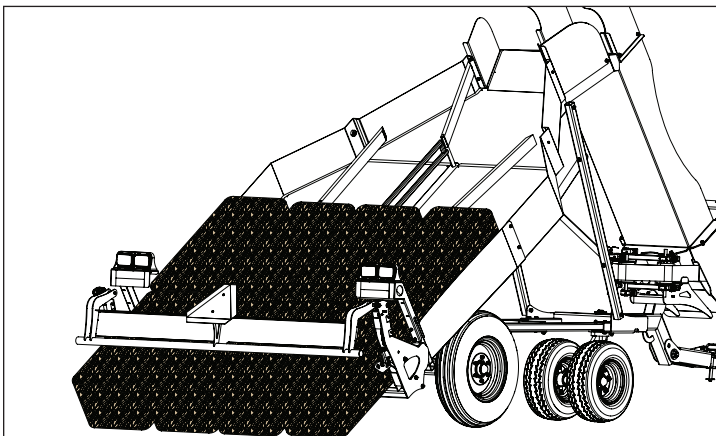

5. Assembly

The unit ships in the folded position as shown.

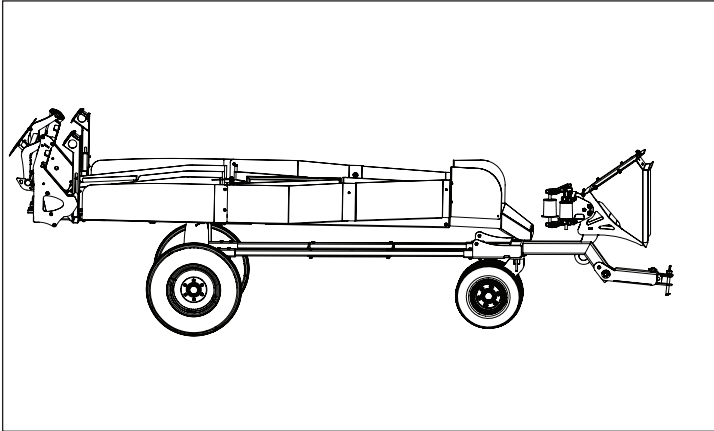

WARNING



Crush Hazard

The unit weighs approximately 1100 pounds and may cause serious injury or death if it falls on a person. Use a lifting device with adequate capacity to support the bed. Use extreme caution when working under the bed when it is supported by a lifting device. Do not allow bystanders to walk under or stand near the bed when it is supported by a lifting device.

Chock the wheels to prevent the unit from moving during the next steps.

1. Using a suitable lifting device, raise the front of the accumulator bed to install the front supports. The accumulator bed assembly weighs approximately 1100 pounds.

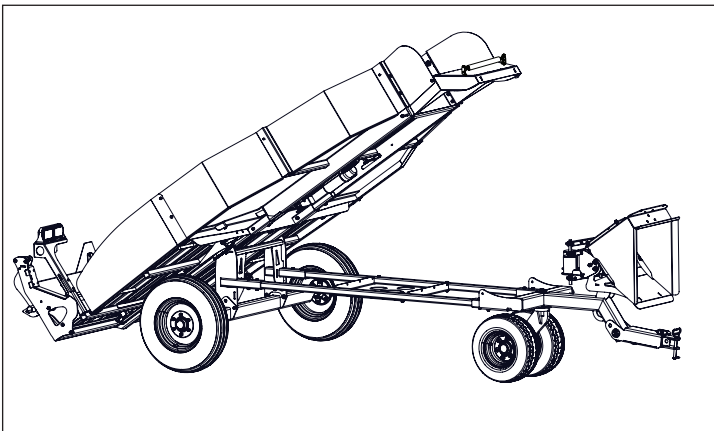

2. Bolt the front supports in place using four 1/2 x 3" bolts and serrated flange nuts provided. Tighten the bolts to the proper torque value.

NOTE: Make sure to install these bolts from the inside, with the nut on the outside of the unit.

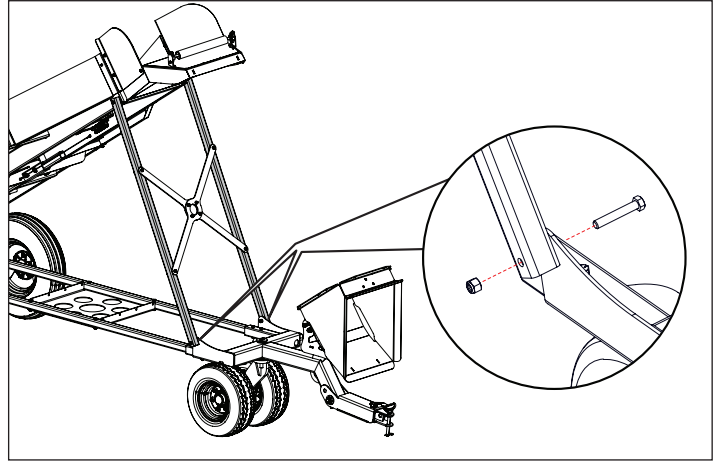

3. Attach the main chute using six 3/8 x 3/4" serrated flange bolts and nuts (1) at the bottom and two 3/8 x 1" carriage bolts (2) with serrated flange nuts at the top. Do not fully tighten the bolts.

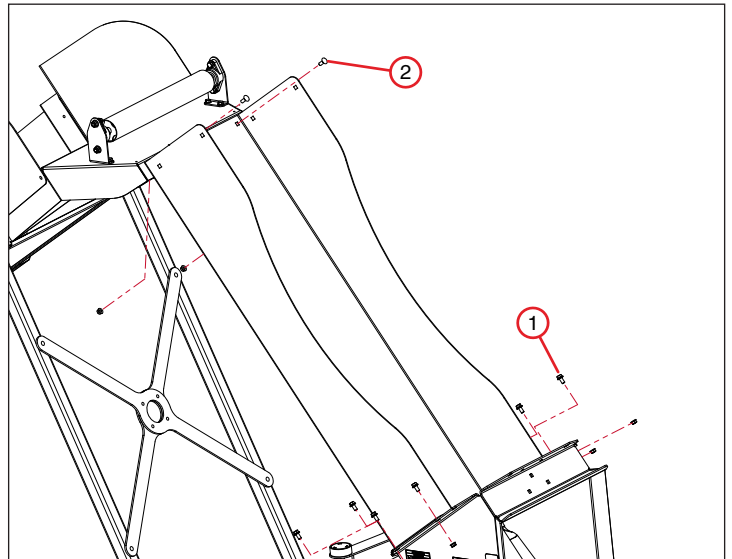

4. Bolt the chute extensions to the main chute using two 3/8 x 3/4" carriage bolts with serrated flange nuts on each side. Ensure carriage bolts are on the inside.

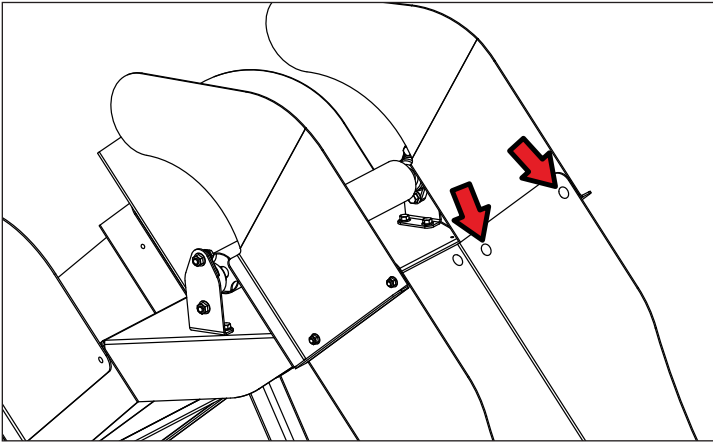

5. Tighten all the bolts that were previously left loose to the proper torque value. Tighten the bolts in the order that they were assembled, as shown.

NOTE: Refer to "11.10 Standard Torque Values" on page 36 for the proper torque value for all fasteners.

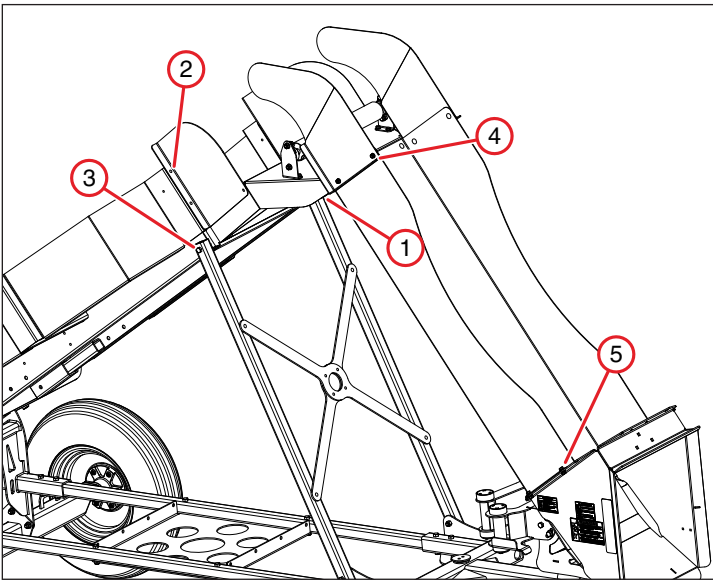

6. Set-up

User Safety Training

⚠ WARNING

Failure to follow these safety instructions could result in death or serious injury.



Roll Away Hazard

Before leaving the tractor seat, make sure the engine is stopped, the transmission is placed in park, the key is removed, and the parking brake is set.



Crush Hazard

The tractor should be equipped with a Roll Over Protective Structure (ROPS) and a seat belt. A crushing hazard could occur if the driver is ejected from the seat while the tractor is in motion. Fasten the seat belt whenever the tractor is moving.



Crush Hazard

The weight of the tractor, plus the implement, if it rolls onto a person, could cause serious crushing injury or death.



Stay Clear

Keep hands and clothing clear of moving parts. Do not clean, lubricate, or adjust your equipment while it is moving.



Rollover Hazard

To avoid serious injury or death from falling off tractor, equipment run-over, rollover, or crushing:

- Use ROPS equipped tractor.
- Keep ROPS locked in the UP position.
- Only operate the equipment when seated in the tractor seat.
- Always fasten seat belt when operating the tractor.
- Use caution when transporting over uneven terrain and slow down for turns.

The tractor must be equipped with a Roll Over Protective Structure (ROPS) (tractor cab or roll bar) and seat belt to protect the operator from falling off the tractor, especially during a roll-over where the driver could be crushed and killed. Only operate the tractor with the ROPS in the raised position and seat belt fastened.

SAFETY INSTRUCTIONS

Failure to follow these safety instructions could result in injury or equipment damage.



Train Unfamiliar Users

It is the owner's responsibility to make sure any person using the unit, especially if it is loaned or rented, has been thoroughly trained on its proper and safe use.

- Be certain only physically-able persons will use the unit.
- Users who have not read and understood all operating and safety instructions are not qualified to use the unit.
- If the elderly are assisting with the work, their physical limitations need to be recognized and accommodated.
- Never allow children to operate equipment.

6.1 Tractor Requirements



Tractor Owner/Operator Manual

Always refer to the tractor owner's manual to ensure compatibility and maximum safety.

Refer to the tractor and baler Operator's Manual to make sure the tractor used has the power to pull and operate the baler. There is no extra horsepower required for the unit, other than towing.

Operating the baler with a tractor that does not have adequate power may damage the tractor engine.

Operating the equipment with a tractor that does not meet the following requirements may cause tractor or implement damage and be a potential danger to the operator and passersby.

Always review the "controls" section of the tractor Operator's Manual to be familiar with the location,

settings, and function of the tractor controls. Be familiar with all controls before using this equipment.

6.1.1 Equipment and Capabilities

- Approved Roll-Over Protective Structure (ROPS) or ROPS cab and seat belt.
- Tractor Safety Devices; Slow Moving Vehicle (SMV) emblem, lighting, PTO master shield.
- Front end weight, as needed, to maintain 20% weight on front axle.
- To reduce the risk of fire, do not use a tractor with an under frame exhaust.
- A loader with at least 1500 lb. lift capacity is required to handle the grouped bales.

6.2 Tractor Safety Devices

If transporting or operating the tractor and implement on a public roadway, the tractor and/or implement must be equipped with proper warning lighting and a Slow Moving Vehicle (SMV) emblem, which are clearly visible from the rear of the unit. Lights and a SMV emblem must be attached directly to the implement if the visibility of the tractor warning signals are obscured.

Maintain all manufacturer-equipped safety shields and guards. Always replace shields and guards that were removed for access to connect, service, or repair the tractor or implement. Never operate the tractor PTO with the PTO master shield missing or in the raised position.

6.3 Chamber Extension Assembly

1. Make sure the baler and accumulator are parked on level ground, and remove all chutes/mechanisms from the back end of the bale chamber. You will need a 9/16" socket or wrench.
2. Assemble the three piece chamber extension using six 3/8 x 3/4" flange bolts and 3/8" flange nuts provided. Do not fully tighten the bolts at this time.

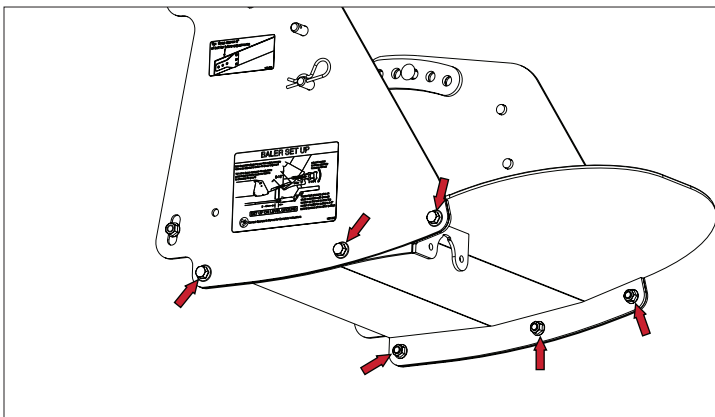

3. Loosely bolt the chamber extension onto the baler using four 3/8 x 1-1/4" carriage bolts and 3/8" flange nuts provided. Make sure the carriage bolt heads are on the inside.

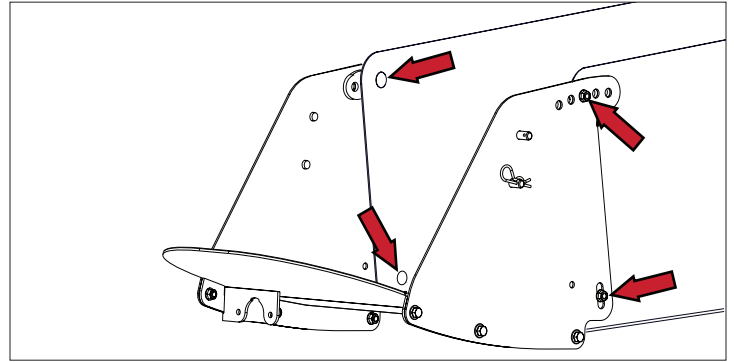

6.4 Baler-Accumulator Hook Up

CAUTION

Use caution when connecting the accumulator to the baler. The unit's wheels should be securely chocked to prevent unwanted movement. Keep hands and feet clear of pinch points between the baler draw-bar and unit.

Proper baler hitch set up is essential to successful cornering with the hay accumulator.

1. Set the length of the baler hitch so that the hitch pin is 2 to 4" behind the tip of the chamber extension. If necessary, add a hitch length setting by drilling a hole in the draw-bar. The hitch must be centered left / right below the chamber.

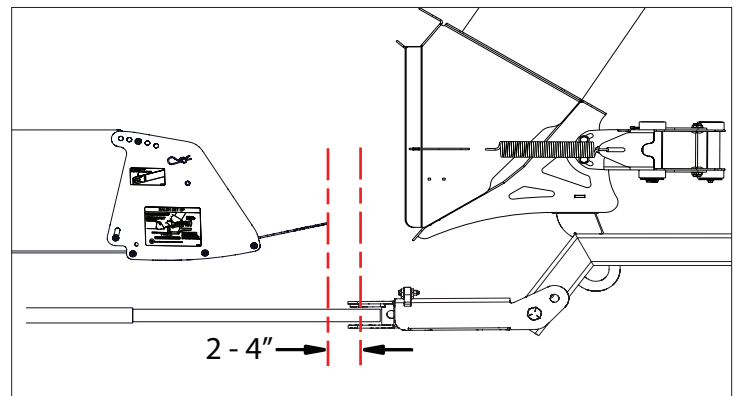

NOTE:

- If the baler hitch is not centered, you will need a New Holland® centering hitch adapter, refer to "6.6.1 New Holland® (NH) Balers" on page 24, from Norden Mfg.
- If the baler hitch is too short, New Holland offers a longer hitch tube refer to "6.6.1 New Holland® (NH) Balers" on page 24

- Most John Deere® balers may need a hitch extension for proper hitch length, refer to “6.6.2 John Deere® (JD) Balers” on page 24.
- If your accumulator is supplied with a winch on the upright, it can be used to help bring accumulator closer to the baler.

2. Insert Hitch Pin. Make sure the hitch is pushed all the way in to the retracted position.

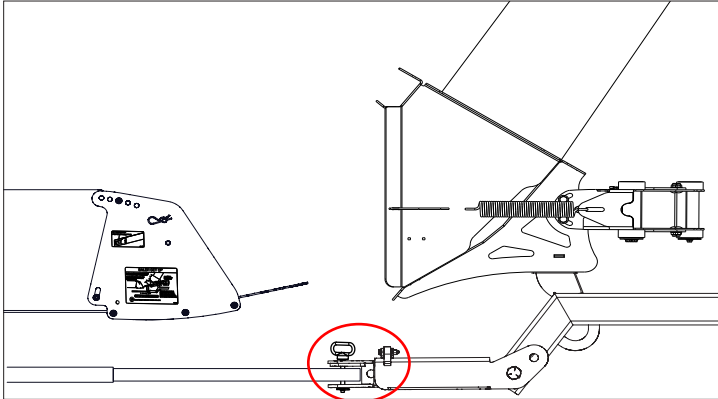

3. Select which ever hole that aligns the bottom plate of the bale chamber extension to a point 8-10” back from the base chute bottom edge as shown. This can be fine tuned later if needed to achieve optimum results.

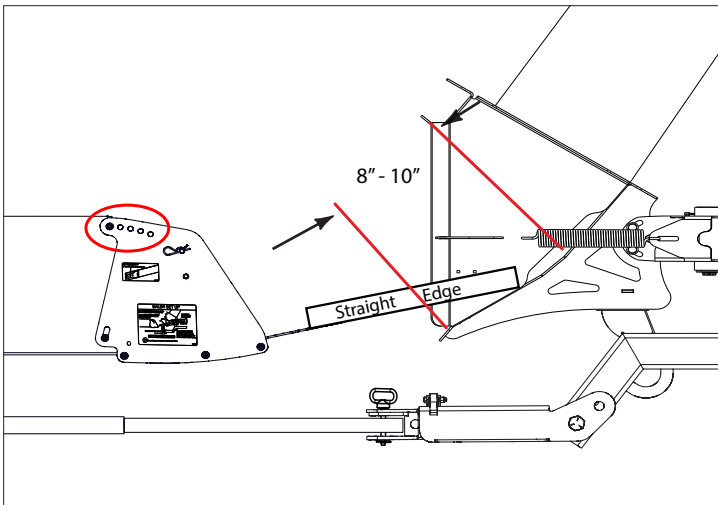

4. Tighten the four carriage bolts on the sides of the chamber extension first, then the six flange bolts on the bottom. Install Lighting Cable using 5/16” bolts, washers and nylock nuts.

Route the lighting cable through the baler in a path that avoids all moving parts.

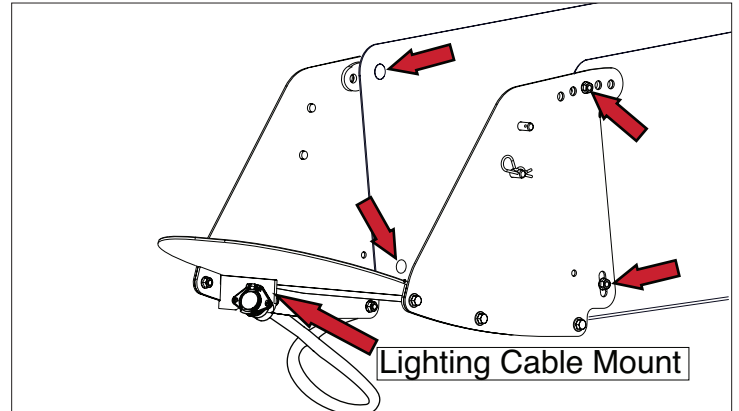

5. Fasten the installed belt plate to the pin on passenger side of the chamber extension. There are two pins (A) and (B); use the pin that makes the belt most nearly level.

NOTE: Position the belt with the large belt plate next to the chamber extension.

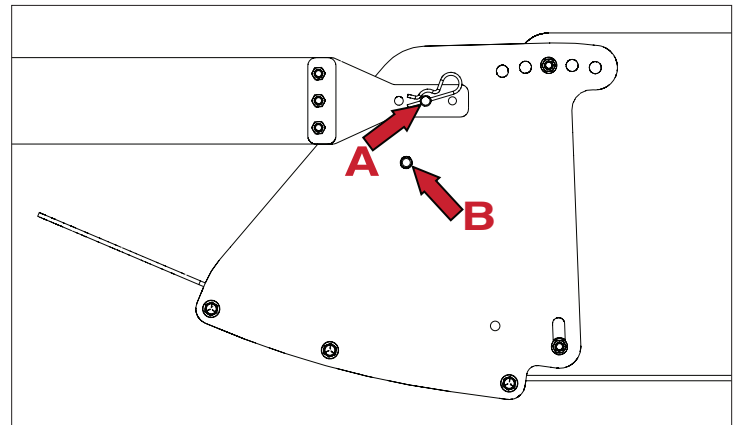

6. Route the belt through the slots in the base chute.

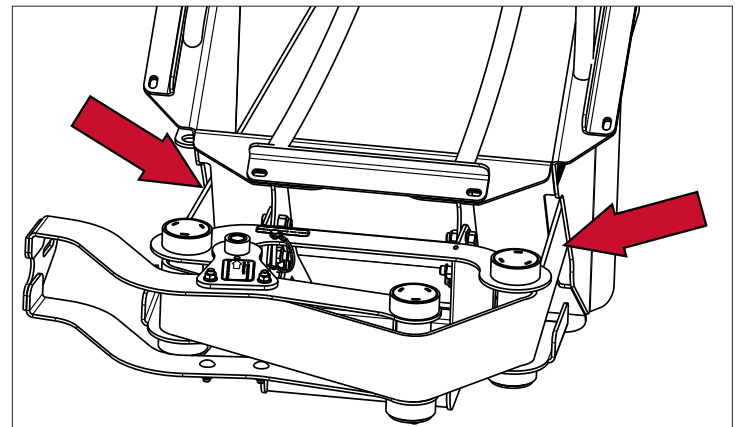

7. Make sure the tensioner spring is unhooked.

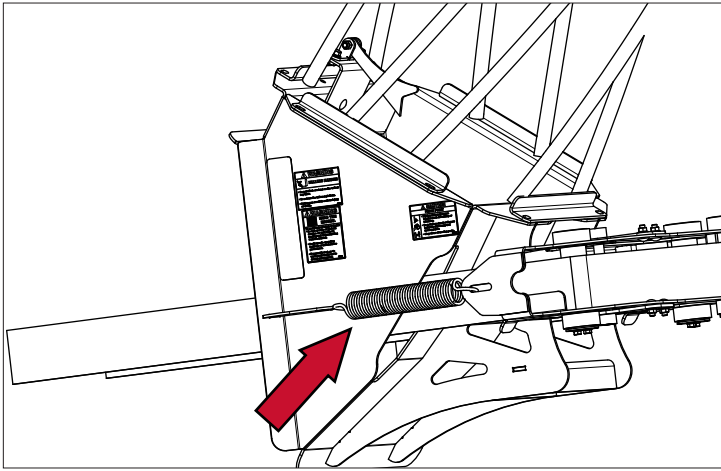

8. Place the pin in the setting up position.

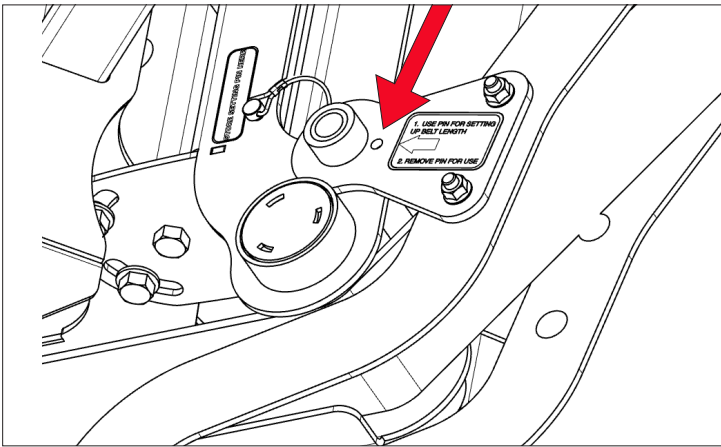

9. On the driver side, temporarily mount the large end plate on the appropriate pin using the same hole as the other side.

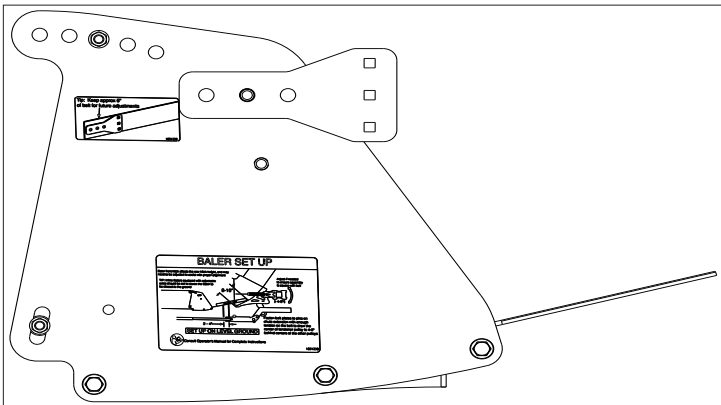

10. Hold the belt on the outside of the large end plate, pull the belt snug and mark a line on the belt even with the back end of the plate.

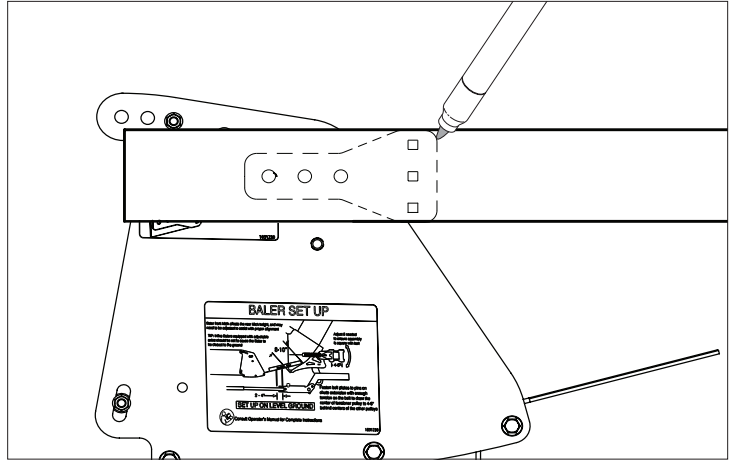

11. Place the belt on a flat surface. Remove the large end plate from the pin and place it on the belt with the back edge on the previously marked line. Mark the hole locations.

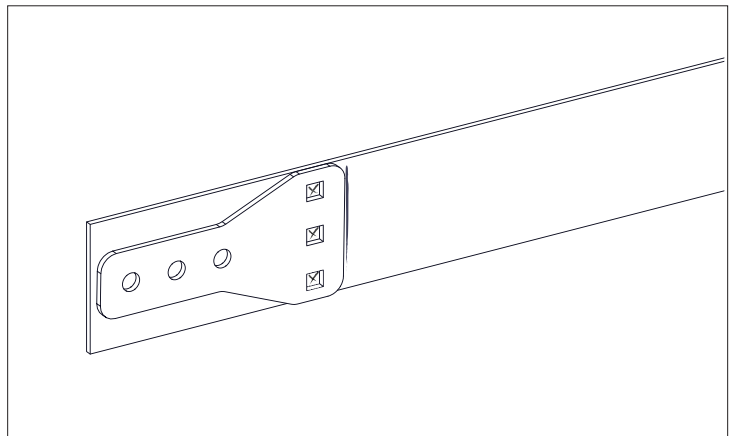

12. Use a 3/8" leather punch (recommended) or a 7/16" drill to make three holes through the belt at the marked locations.

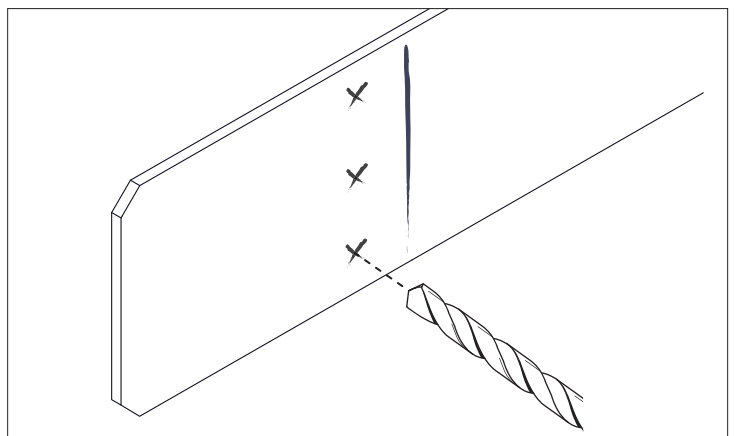

13. Install the belt end plates using three 3/8 x 1" carriage bolts and flange nuts. Position the large end plate on the inside (nearest to the bale chamber). Remove the excess belt length leaving about 6" for future adjustments.

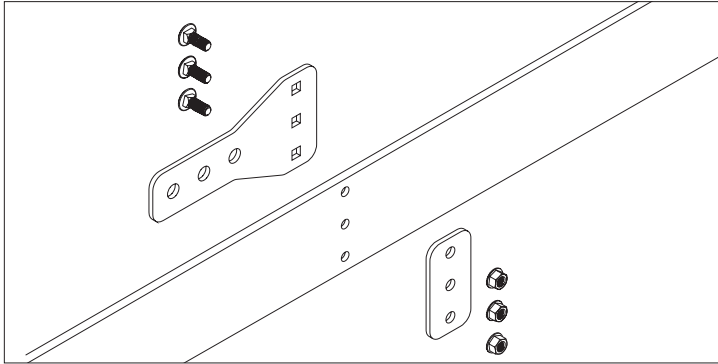

14. Remove Pin in the tensioner from the setting up position and place into storage hole. .

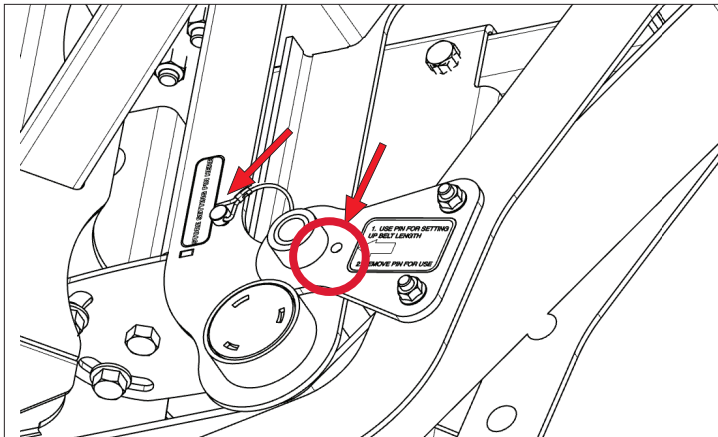

15. Re-attach the tensioner spring and ensure that the belt tensioner assembly is square with the belt by adjusting the angle of the belt tensioner assembly at its mounting point on the base chute.

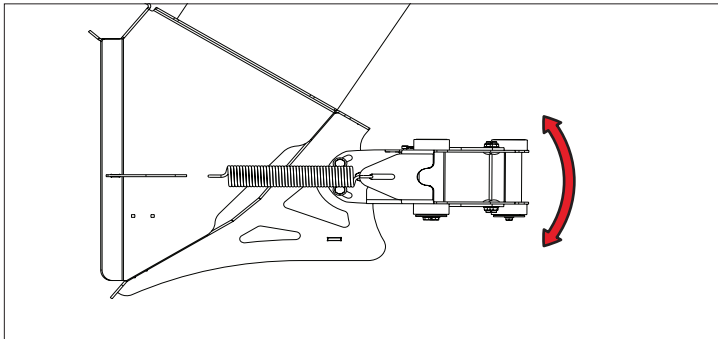

16. Fasten the belt plate to the previously selected pin on the side of the Chamber Extension.

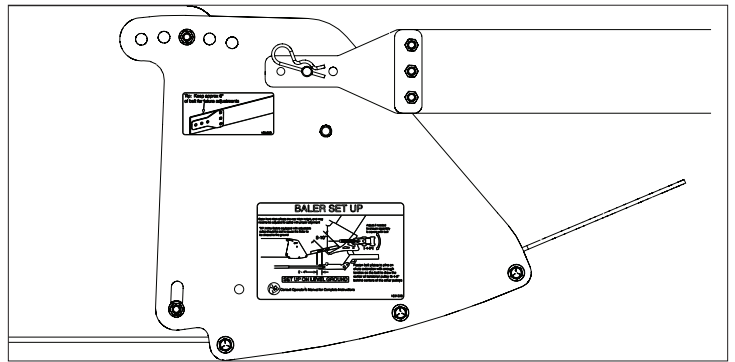

TIP: If your accumulator is equipped with a winch on the upright, hook the winch to the tensioner using the same slot as the spring, and crank to relieve tension. After attaching belt plates, loosen winch cable and remove from the Tensioner

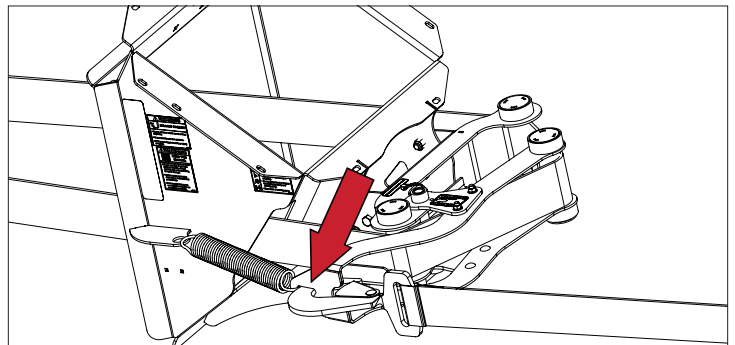

Once hooked up, the tensioner spring should be stretched approximately 15"-16"

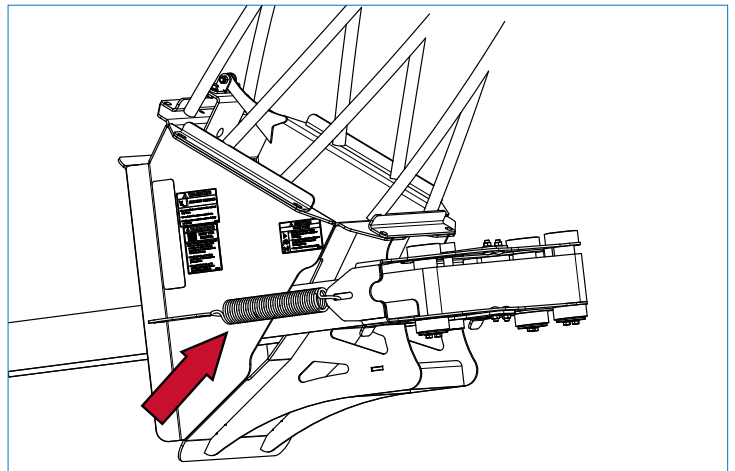

6.5 Baler Chamber Tension Settings

This is dependent on your requirements for the size of bale that you want to make. First loosen the bale chamber tension nearly all the way to compensate for the back pressure caused by the chute. Then adjust the chamber pressure to reach the desired bale size. Wedges may need to be removed from the chamber. Check bales after first load is released for proper tightness. Adjust pressure accordingly.

6.6 Baler Hitch Special Requirements

NOTE: For more information and complete instructions see our website, www.nordenmfg.com for our current Hitch Guide.

Center Hitch, #1008091, JD Hitch, #1009471, and Massey 1840 Hitch Spacers, #1035690 can be ordered through your Dealer or by calling Norden Mfg:

Phone: 877-296-5851
Fax: 440-693-4336
E-mail: parts@nordenmfg.com

6.6.1 New Holland® (NH) Balers

• Older New Holland® (NH) Balers

1987 and older NH balers have the hitch on the right hand side of the chamber. Norden Mfg. offers a center hitch adapter to center the hitch. This kit also includes extension brackets to help level the Chamber Extension where balers have angled chambers.

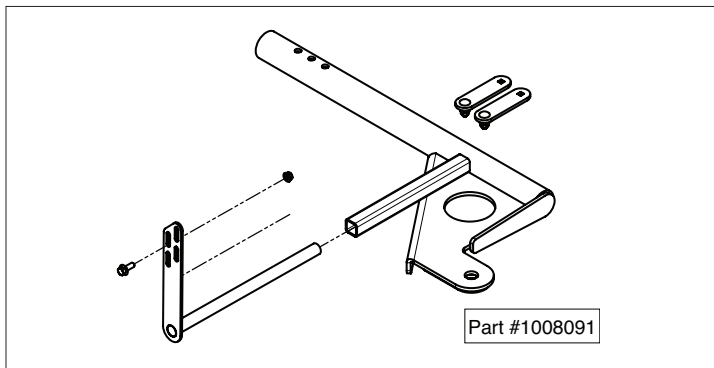

• Newer New Holland® Balers

1988 and newer NH balers have a hitch centered underneath the chamber. The hitch may need to be modified to meet the dimensions given in “6.4 Baler-Accumulator Hook Up” on page 20.

SAFETY INSTRUCTIONS

Consult the baler manufacturer before making any modifications to the baler.

If you have a New Holland® baler with an extended chamber, you may need a longer tube. New Holland® offers a longer hitch tube for the wagon hitch kit. KA ID: KA00596124 / 283048

The wagon hitch kit is common across several series of small square balers. The hitch tube in the kit has an overall length of 865 mm (34 inches).

A longer hitch tube (PN# 84134280) with overall length of 1185 mm (46-5/8”) is available through New Holland Agriculture®

6.6.2 John Deere® (JD) Balers

The hitch on the JD baler may need to be extended to meet the dimensions given in “6.4 Baler-Accumulator Hook Up” on page 20. Norden Mfg. offers a special hitch extension for John Deere® balers.

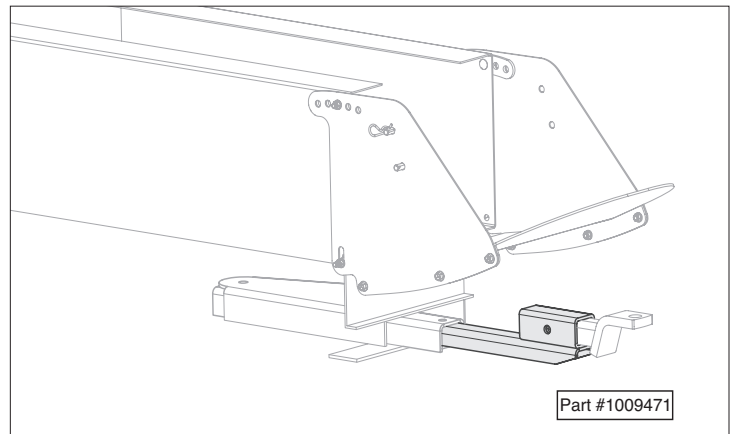

6.6.3 Massey 1840 Hitch Spacers

The Massey 1840 hitch is at times too high. Using Hitch Spacers will lower the hitch allowing it to properly align with the Accumulator Hitch.

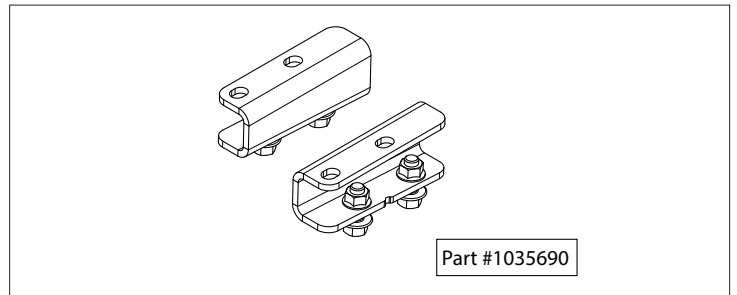

6.6.4 In-line Balers

In-line balers should need little or no modifications.

7. Operation

7.1 Operating Safety

WARNING

Failure to follow these safety instructions could result in death or serious injury.



Roll Away Hazard
Never leave equipment running unattended. When

halting operation, even for a short time, set the tractor or towing vehicle brakes, disengage the PTO, shut off the engine, and remove the ignition key.



Fall Hazard

Do not climb or stand on the unit for any reason. Falling can result in serious injury or death.



Overturn Hazard

DO NOT operate on steep slopes as overturn may result. Overturn can result in serious injury or death.

SAFETY INSTRUCTIONS



Be especially observant of the operating area and terrain, watch for loose fill, holes, rocks, or other hidden hazards. Always inspect the area prior to operation.



Pick the most level route when transporting across fields. Avoid the edges of ditches or gullies and steep hillsides. Be extra careful when working on inclines.



Periodically clear the hay accumulator of loose hay to prevent buildup of dry, combustible materials. Do not climb or stand on the accumulator to remove a bale.



Maneuver the tractor or towing vehicle at safe speeds.



Allow for the unit's length when making turns.

7.2 Pre-Operation Checklist

Before each use of the unit, the following areas should be checked.

Checklist Before Each Use	
✓	Task
	Make sure the unit is positively attached to the baler draw-bar. Refer to "6.4 Baler-Accumulator Hook Up" on page 20.
	Make sure the tires are inflated properly and the lug nuts are tight.
	Check the condition of the belt.
	Visually inspect the Hay Accumulator for any loose bolts, worn parts or cracked welds, and make necessary repairs.
	Make sure all retainer clips and pins are in place.
	Make sure the belted base chute tensioner and end gate operate freely.
	Make sure the operating area is clear, especially of children and animals.

7.3 Attaching to Baler

Use caution when connecting the unit to the baler. Keep hands and feet from under the equipment and clear of pinch points between the draw-bar and accumulator hitch.

WARNING

Not following these safety instructions could result in death or serious injury.



Crush Hazard

Crush hazard between hitch and implement. Do not allow anyone to stand between the hitch and implement during hook-up operations.



Use caution when connecting the unit to the baler. The wheels should be securely chocked. Keep hands and feet clear of pinch points between the baler draw-bar and unit.

1. Board the tractor and start the engine. Back the baler up to the unit's hitch until the holes in the draw-bar and clevis are aligned.

2. Stop the tractor, place the transmission in park or neutral, apply the parking brake, shut down the engine, and remove the key. Wait for all motion to come to a complete stop before exiting the tractor.
3. Insert a high strength draw-bar pin through the clevis and draw-bar holes and install the retaining pin. Do not use a homemade or shop made pin.

⚠ WARNING

Failure to follow these safety instructions could result in death or serious injury.



Crush Hazard

Unexpected separation of the unit from the baler could cause death or serious injury. Use only an OEM high strength draw-bar pin. Do not use a homemade or shop made pin.

Fasten the guide belt plates to the pins on the side of the chute extension using the hairpin retainers.

7.3.1 Break In

To quickly and effectively “break in” the unit, apply furniture polish, baby powder, or cooking spray to the surface of the bed to make the bales slide easier. After a couple dozen bales have been through the unit, the surface will be buffed enough to slide without spray.

7.3.2 Stuck Bale Removal

If a bale should get caught in the chute, stop baling, place the transmission in park or neutral, apply the parking brake, shut down the engine, and remove the key. Wait for all motion to come to a complete stop before exiting the tractor to safely remove the bale. Use a pole, broomstick, or other suitable tool to remove the bale. Do not climb or stand on the unit to remove a bale. If the bale cannot be manually dislodged, break the bale and remove the loose hay from the unit.

NOTE: Periodically remove built up hay from Bale Roller to prevent jamming.

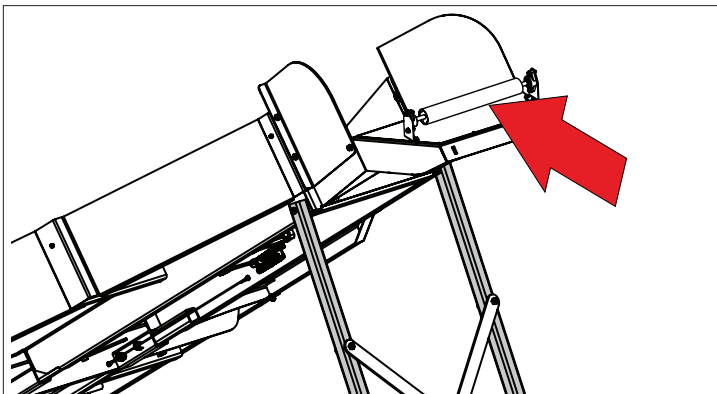

⚠ WARNING

Failure to follow these safety instructions could result in death or serious injury.



Fall Hazard

Do not climb or stand on the unit for any reason. Falling may result in serious injury or death.

7.4 Operating Procedures

7.4.1 Cornering

When properly set up, the unit will corner without difficulty. If the hitch configuration is not as specified in this manual, problems may occur. Refer to “6.4 Baler-Accumulator Hook Up” on page 20. Once everything is properly configured, contact Norden Mfg. if additional help is needed.

7.4.2 Hillside

⚠ WARNING

Failure to follow these safety instructions could result in death or serious injury.



Overturn Hazard

DO NOT operate on steep slopes as overturn may result. Overturn can result in serious injury or death.

The Norden Hay Accumulator works well on moderate hillside. Operate up and down (not across) intermediate slopes. Avoid sudden starts and stops. If problems persist, call Norden Mfg. for service. If the back gate doesn't close going up a hill, an SMV backer plate can be ordered to add extra weight (#1017720) Refer to “12.1 Ordering Parts” on page 38.

7.4.3 High Moisture Hay

The bed floor is covered with stainless steel to help the bales slide. Baling hay with a moisture content of 25% or over is not recommended.

7.5 Detaching From Baler

⚠ CAUTION

Use caution when disconnecting the unit from the baler. Keep hands and feet from under the equipment and clear of pinch points between the draw-bar and unit's hitch.

WARNING

Failure to follow these safety instructions could result in death or serious injury.



Crush Hazard

Crush hazard between hitch and implement. Do not allow anyone to stand between the hitch and implement while detaching the unit.

1. Park the tractor, place the transmission in park or neutral, apply the parking brake, shut down the engine, and remove the key. Wait for all motion to come to a complete stop before exiting the tractor.
2. Chock the wheels before attempting to disconnect it from the baler. Use extreme care to keep feet and hands clear of any pinch points between the draw-bar and hitch.
3. Detach the guide belt from the pins on the sides of the bale chamber.
4. Remove the draw-bar pin from the clevis and draw-bar.
5. Board the tractor and start the engine. Drive the tractor and baler away

8. Troubleshooting

8.1 Front Gate Bounces in Home Position

If the front gate bounces away from the right bumper and catches bales, more return spring tension is needed.

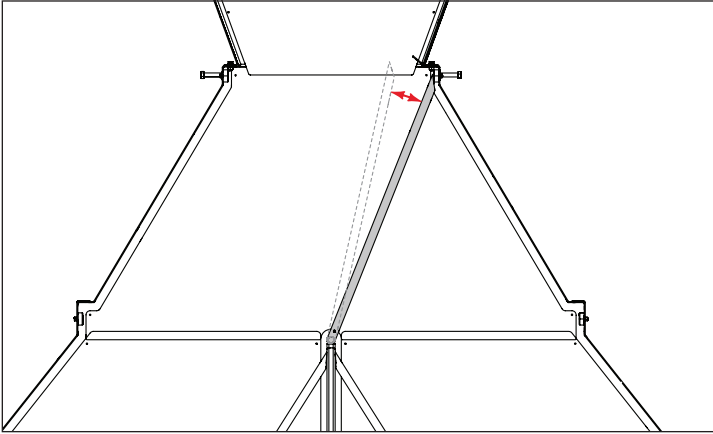

1. Loosen the two screws on the split collar and rotate the gate arm downward (clockwise).

NOTE: The factory setting for the return spring length is 10-3/8".

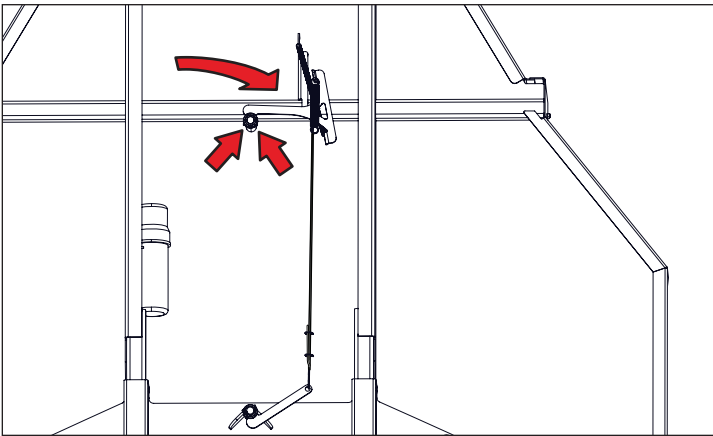

2. Shorten the cable to maintain the same position for the switch arm.

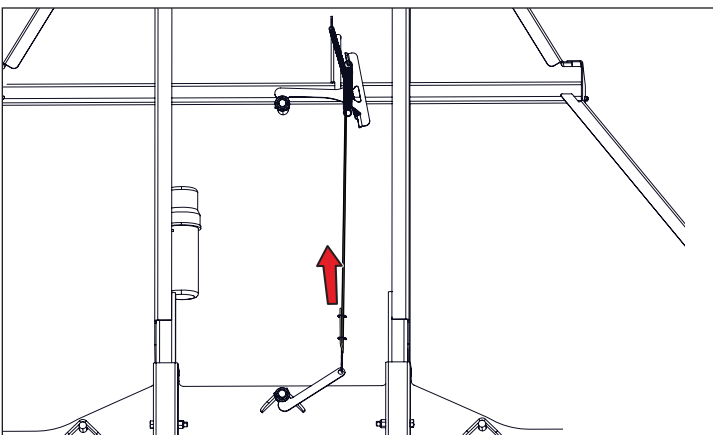

8.2 Front Gate Bounces in Open Position

If the front gate bounces away from the left bumper and catches bales, more actuating spring tension is needed.

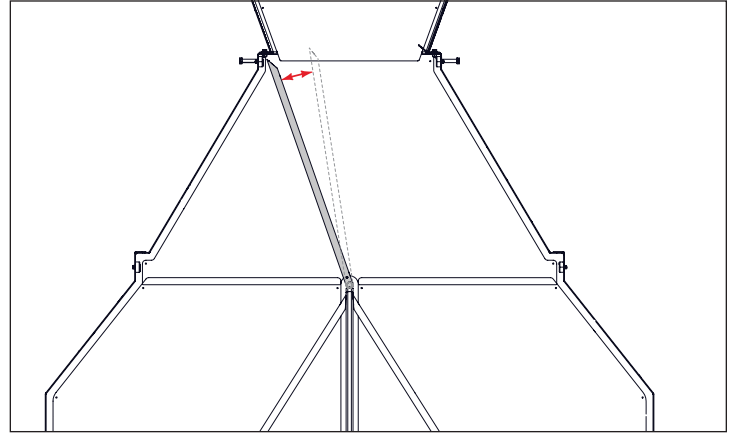

1. Loosen the two screws and rotate the gate arm upward (counterclockwise).

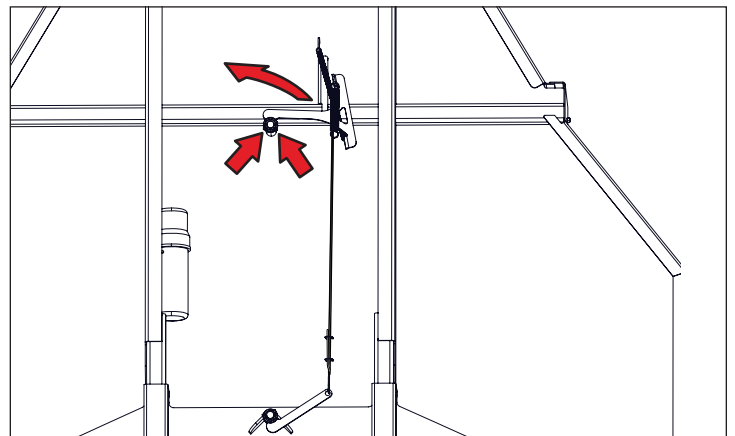

2. Lengthen the cable to maintain the same position for the switch arm.

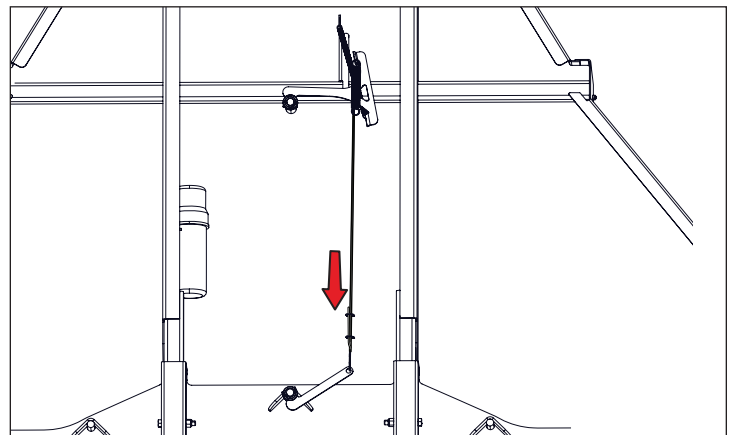

8.3 Back Gate Trip Adjustments

1. The back gate trip reach (1) moves laterally to engage the pin on trip flipper (2). It must move easily and be free of any obstruction. If the back gate fails to open, check for hay or other material blocking the motion of the trip reach.

NOTE: Ensure the pin on trip flipper (2) is rounded and sooth. File smooth if needed and grease.

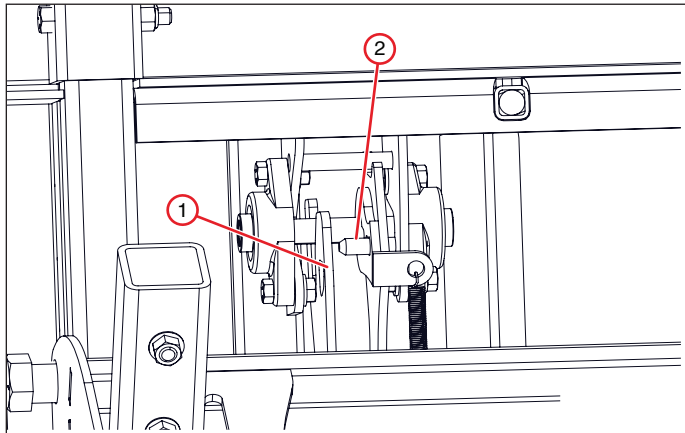

2. When the trip reach is pushed over to the right by trip slider (3), it must not contact the bolt heads (4) on the bearing mount. Make sure there is clearance to the bolt heads when the trip reach is in contact with the trip slider.

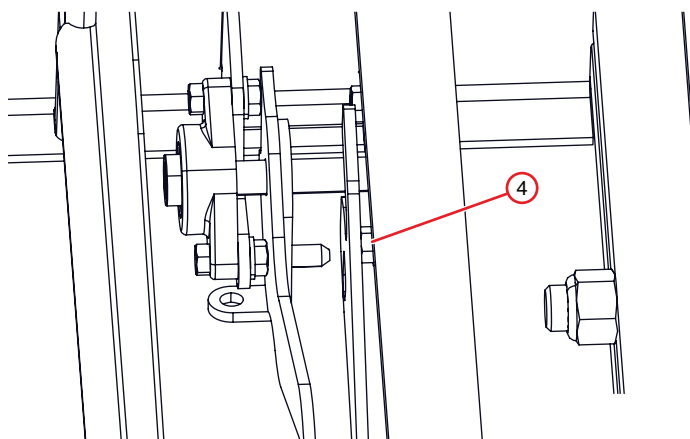
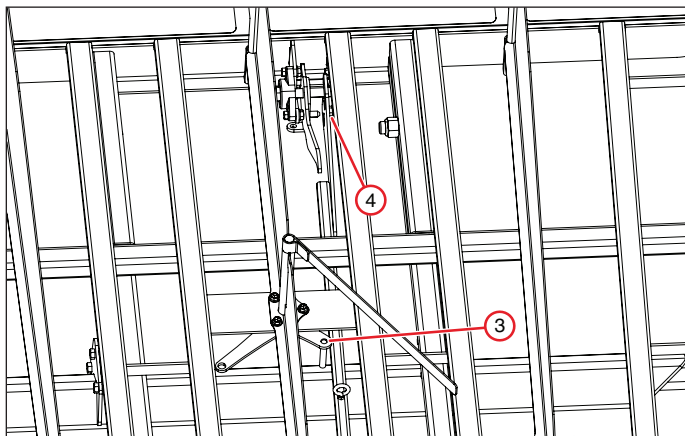

3. The trip reach should engage the pin at the forward edge of the slot. If it engages near the rear of the slot, there may not be enough travel to release the gate.

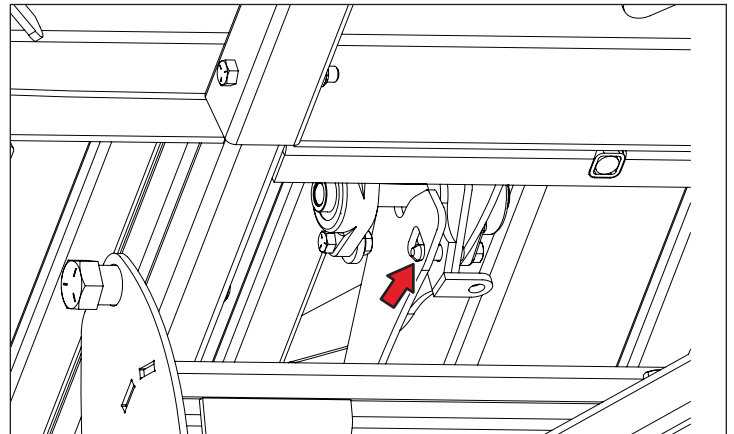

4. To adjust the trip reach, loosen the four socket head cap screws on the backshaft ear. Rotate the ear to adjust the front to back position of the trip reach. Slide the ear left or right to adjust the lateral position of the trip reach.

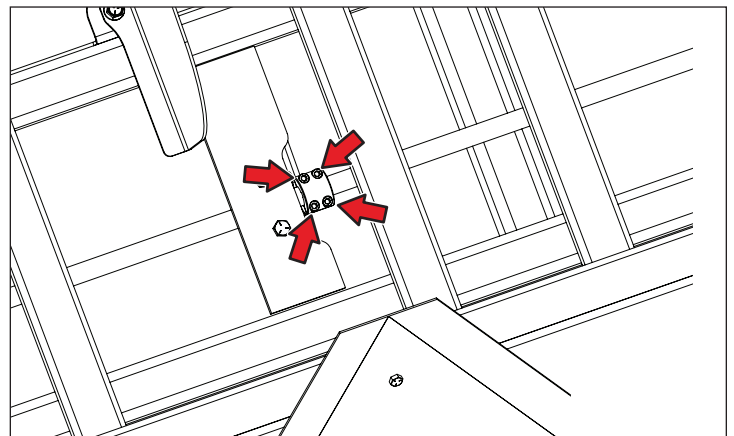

NOTICE

Equipment or property damage can result if instructions are not followed.

Use caution when tightening socket head cap screws. Over tightening may cause screws to strip. Use part #1016500 when re-ordering socket head cap screws.

Norden Mfg.

Phone: 877-296-5851

Fax: 440-693-4336

E-mail: parts@nordenmfg.com

9. Transporting

9.1 General Safety

SAFETY INSTRUCTIONS

 Towing the unit requires care! Both the unit and tow vehicle must be in good working condition. Securely attach the unit to the tow vehicle using a high strength, appropriately-sized hitch pin with a mechanical retainer and attach safety chain.

 Make sure the safety chain from the unit is securely fastened to the tow vehicle.

 Check the tires for tread wear, inflation pressure, and overall condition before towing the unit.

 Inspect the hitch and coupling for wear or damage. **DO NOT** tow the unit using a defective hitch or coupling!

 Make sure the lug nuts holding the wheels are tight and that none are missing.

 When towing the unit on the highway, make sure the “Slow Moving Vehicle” placard is clearly visible.

 Do not allow anyone to stand between the tongue or hitch and the towing vehicle when backing up to the unit.

 Make sure that the area is clear of children, animals, and other obstacles before moving the unit. This is particularly important with higher noise levels and quiet cabs, as you may not hear people shouting.

 Do not allow anyone to ride on the unit.

9.2 Safety Chain

WARNING

 **Unexpected Separation Hazard**
If the safety chain does not have a current certification tag, do not tow the unit until properly certified chains are installed. Substandard safety chains could allow the unit to separate from the tow vehicle, resulting in equipment damage and personal injury.

SAFETY INSTRUCTIONS

If the unit will be transported on a public highway, a safety chain must be attached to the tow vehicle.

 Always follow state and local regulations regarding a safety chain when towing farm equipment on a public highway.

 Be sure to check with local law enforcement agencies for any local regulations or restrictions.

Do not use any device other than an approved safety chain. Only a safety chain (not an elastic or nylon/plastic tow strap) should be used to retain the connection between the tow vehicle and the unit in the event of separation of the primary attaching system. Install the safety chains by crossing the chains under the tongue and secure to the hitch.

9.3 Highway and Transport Operations

SAFETY INSTRUCTIONS

- Operate the towing vehicle from the operator’s seat only.
- Never use independent braking when towing the unit, as loss of control and/or upset of the unit may result.
- Always drive at a safe speed relative to local conditions, and ensure that your speed is low enough for an emergency stop to be safe and secure. Keep speed to a minimum.
- Reduce speed prior to turns to avoid the risk of overturning.
- Avoid sudden uphill turns on steep slopes.
- Always keep the tractor or towing vehicle in gear to provide engine braking when going downhill. Do not coast.
- Use approved accessory lighting, flags, or other necessary warning devices to protect operators of other vehicles on the highway during daylight and nighttime transport. Various safety lights and devices are available from your dealer.
- When driving the tractor and equipment on the road or highway, use flashing amber warning lights and a slow moving vehicle (SMV) identification emblem.

- Some localities prohibit the use of flashing amber lights. Local laws should be checked for all highway lighting and marking requirements.
- Be a safe and courteous driver. Always yield to oncoming traffic in all situations, including narrow bridges, intersections, etc. Plan your route to avoid heavy traffic.
- Be observant of bridge load restrictions. Do not cross bridges rated lower than the gross weight at which you are operating.
- Watch for overhead obstructions and side clearances while transporting.

NOTICE

Always operate equipment in a position to provide maximum visibility at all times. Make allowances for increased length and weight of the equipment when making turns, stopping, etc.

9.3.1 Setting the Hitch for Transport

When transporting, the swivel dolly must be clear of the ground. (Not necessary for towing behind baler).

1. Using a suitable lifting device, raise the front of the unit until the front wheels are off the ground. A jack mount is provided on the left front of the frame for this purpose.

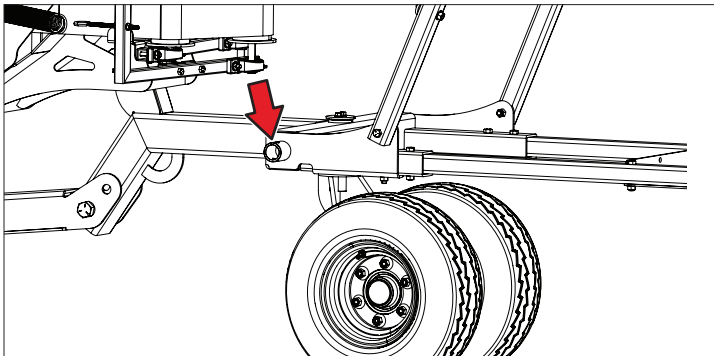

2. Extend tongue out, Insert a 1" diameter hitch pin or Grade 8 bolt in the provided hole in the tongue. Install a retainer clip or locking nut, as appropriate.

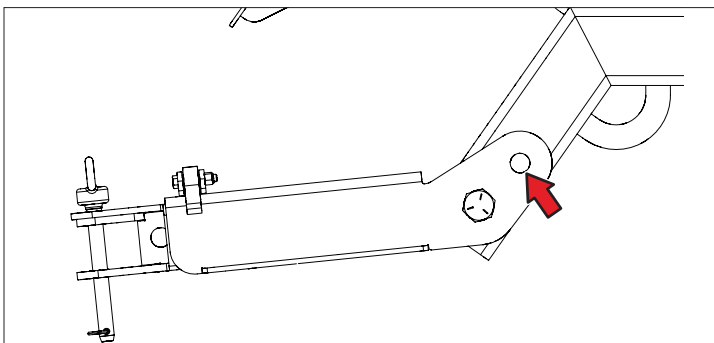

NOTICE

Remove the pin before using the unit.

9.3.2 Lights

The unit is equipped with Agricultural Lights and an Enhanced Flasher Lighting Module to meet ASABE S279 standard. The unit has a 7-pin Agricultural plug. If towing the unit with a vehicle equipped with a 7-pin trailer plug, verify proper operation of the lights before towing.

9.4 Pre-towing Checklist

Checklist before towing	
✓	Task
	Before towing, make sure the maintenance on the tow vehicle and the unit are current. This is very important because towing puts additional stress on the tow vehicle.
	Check and correct the tire pressures on the tow vehicle and the unit.
	Make sure the hitch, clevis, and any other equipment that connects the unit and the tow vehicle are properly secured and adjusted. Always inspect the hitch and tongue for cracks or abnormal wear when hooking up.
	Make sure the hitch is set up for transport. Refer to "9.3 Highway and Transport Operations" on page 30.

WARNING



Standard Parts Hazard

Use only an OEM certified, hardened draw-bar pin with a retainer clip. Do not use homemade pins, bolts, or any other type of retaining device. Always install the retainer clip, making sure the hitch and unit are securely fastened to the tow vehicle.

Using a pin not intended for this type of towing can result in unexpected separation of the unit from the tow vehicle, resulting in equipment damage and personal injury.

3. Attach the safety chain from the unit to the tow vehicle. The safety chain should be long enough for tight turns. Don't allow the chain to drag on the pavement because it will wear the chain links, causing an unsafe condition.
4. Prior to towing, have an observer confirm all running lights, brake lights, turn signals, and hazard lights are working on the tow vehicle.
5. Verify the brakes on the tow vehicle are operating correctly.

10. Storage

WARNING

Failure to follow these safety instructions could result in serious injury and possible death.



Read, understand and follow the Operator's Manual and all safety signs before moving the unit.



Do not permit anyone, especially children, to play on or around the stored unit.

Store the unit in an area away from human activity.

Do not park the equipment where it will be exposed to livestock for long periods of time. Damage and livestock injury could result.

10.1 Placing in Storage

1. Remove all bales and loose hay from the unit.
2. Thoroughly wash the unit with a pressure washer or water hose to remove all dirt, mud, or debris.
3. Select an area that is dry, level, and free of debris (inside a building is ideal). Move the hay accumulator to its storage area. Disconnect the unit from the baler following the procedure in "7.5 Detaching From Baler" on page 26.
4. Lubricate all grease points. Refer to "11.4 Lubrication" on page 34. Make sure all grease cavities have been filled with grease to displace any trapped water from washing.
5. Touch up all paint nicks and scratches to prevent rusting.

10.2 Removing from Storage

1. Grease all lubrication points. Refer to "11.4 Lubrication" on page 34.
2. Attach the accumulator to the baler following the procedure in "6.4 Baler-Accumulator Hook Up" on page 20.
3. Before placing the unit back into service, replace any worn or defective parts and perform the Pre-Operation Checklist, "7.2 Pre-Operation Checklist" on page 25.

11. Maintenance

11.1 General Information

Preventive maintenance is one of the most cost effective practices that any equipment owner can implement. Taking a few minutes of your time to inspect the unit can save hundreds and even thousands of dollars. These savings can come from:

- Increased operating time (no unscheduled breakdowns in the field).
- Normal wear items will last longer because they have been properly maintained and lubricated.
- Less chance of someone becoming injured due to parts that may fail because of mistreatment or abuse.

Preventive maintenance should only be completed by qualified persons. In no way are these instructions intended to encourage service of the unit by anyone who is not qualified to do so. The overall performance of the unit is directly related to the skill and knowledge of the person performing the service. If the mechanic cannot see potential problems, or is unaware of the signs of potential problems, the service may be a costly waste of time.

Norden recommends after 3-5 years or 50-75,000 bales to have a spring, cable kit, and belt on hand. Refer to "12.12 Spring Kit" on page 48

11.2 Maintenance Safety

WARNING

Failure to comply with the following safety instructions could result in serious injury and possibly even death.



Personal Protection Equipment

Wear close fitting and belted clothing to avoid getting caught in moving parts. Wear personal protection equipment (PPE), which may include safety glasses, safety shoes, gloves, etc., appropriate for the work site and working conditions.

 **Damaged Parts Hazard**
Do not use the unit if any parts are damaged. If the unit is believed to have a defect which could cause it to work improperly, immediately stop using it and remedy the problem before continuing.

  **No Unauthorized Modifications**
Do not modify the unit or safety devices.

Do not weld on the unit. Unauthorized modifications may impair the unit's function, or create safety hazards, and will void the warranty. If the unit has been altered in any way from the original design, the manufacturer does not accept any liability for injury or warranty.



  **Crush Hazard**
Always set the unit on safety stands or on the ground and chock the wheels when performing maintenance.



 **Good Working Condition**
Keep all parts in good condition and properly installed. Fix damage immediately. Replace worn or broken parts.



 **Replacement Parts**
If replacement parts are necessary, genuine factory replacement parts must be used to restore the unit to its original specifications. Unapproved parts could create a safety hazard. The manufacturer will not accept responsibility for damages as a result of the use of unapproved parts.

SAFETY INSTRUCTIONS

The following safety instructions are provided to help prevent injury or limit equipment damage.

  **Safety Equipment**
A fire extinguisher and first aid kit should be readily accessible while performing maintenance on this equipment.

   **Clean Work Area**
Do not leave tools lying around the work area. Follow good shop practices. Keep service area clean and dry. Be sure electrical outlets and tools are properly grounded. Use adequate light.

  **Use the Right Tools**
Use the correct tools, jacks, hoists, or other tools that have the capacity for the job.



Proper Support

Use certified safety stands rated to support the load when working beneath the equipment, or performing repairs, service, or maintenance.

The unit weighs 2000 lbs. Before working underneath, place it on a minimum of four jack stands, with a load rating of at least 2000 lbs. each.

Do not position the jack stands under wheels, axles, or wheel supports, as they may rotate and cause the unit to fall.

Make sure the jack stands are stable and the unit is approximately level. Test the stability of the load before working underneath.

If the unit is attached to the tractor and baler, set the brakes, disengage the PTO and all power drives, shut off the engine, remove the ignition key, chock the tractor wheels, and block the unit before working underneath.

11.3 Pre Maintenance Instructions

1. Before working on the unit, stop the towing vehicle, set the brakes, disengage the PTO, shut off the engine, and remove the ignition key.
2. Never replace hex bolts with less than Grade 5 bolts.
3. After servicing, be sure all tools, parts, and service equipment are removed.
4. Where replacement parts are necessary for periodic maintenance and servicing, genuine factory replacement parts must be used to restore your equipment to original specifications. The manufacturer will not claim responsibility for damages as a result of the use of unapproved parts and/or accessories.

11.4 Lubrication

1. Grease the fittings on the end gate bearings annually with an SAE multipurpose lithium base grease until grease comes out of bushings.

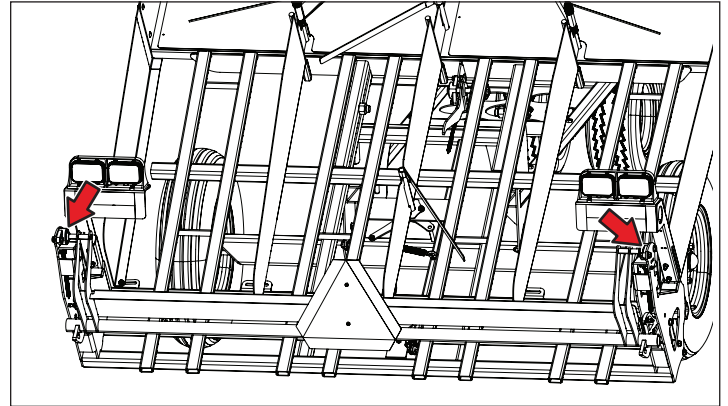

2. Grease the fittings on the back shaft bearings annually with an SAE multipurpose lithium base grease.

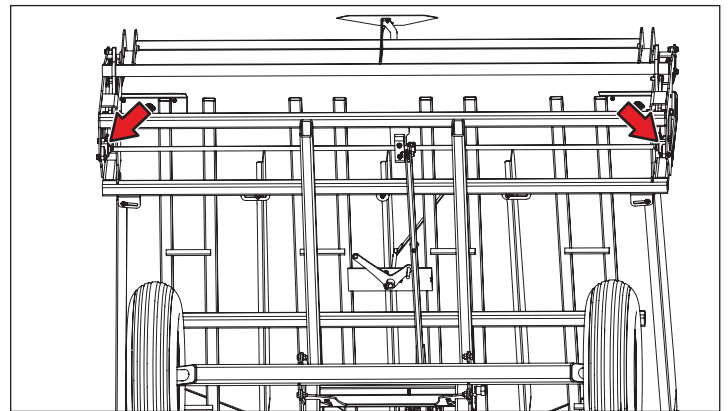

3. Grease the fittings on the trip flipper arm bearings annually with an SAE multipurpose lithium base grease.

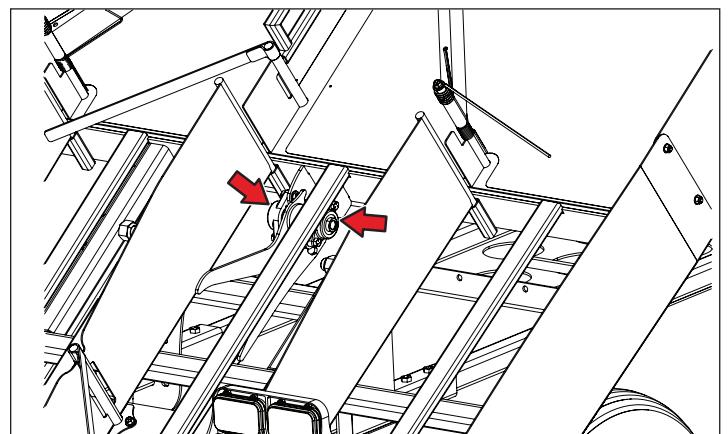

- Grease the fittings on the wheel bearings weekly when in service with an SAE multipurpose lithium base grease.

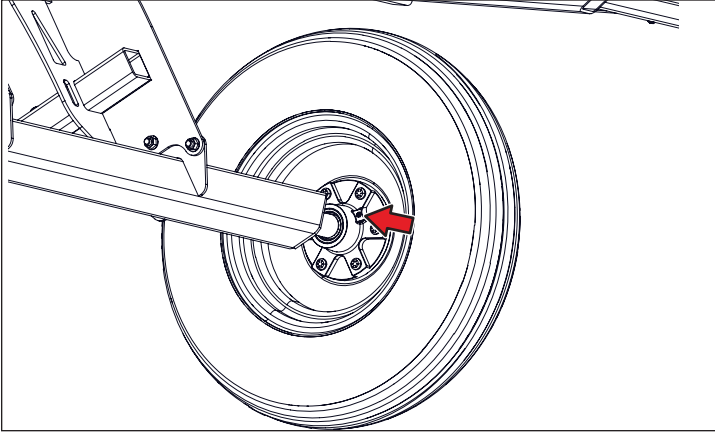

- Grease the fitting on the tongue pivot annually with an SAE multipurpose lithium base grease.

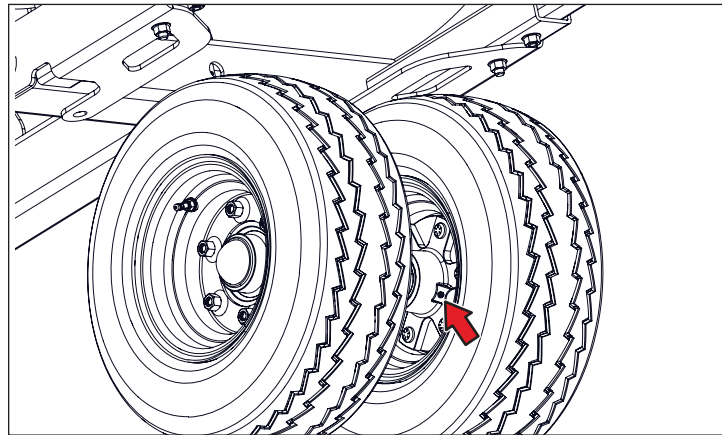
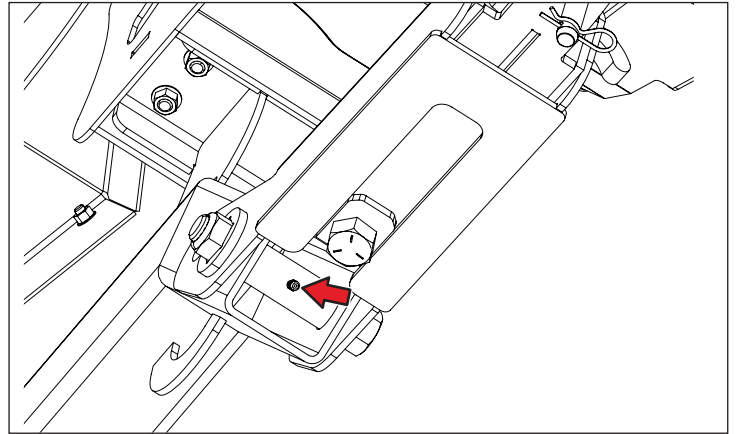

- Grease the fitting on the swivel dolly annually with an SAE multipurpose lithium base grease.

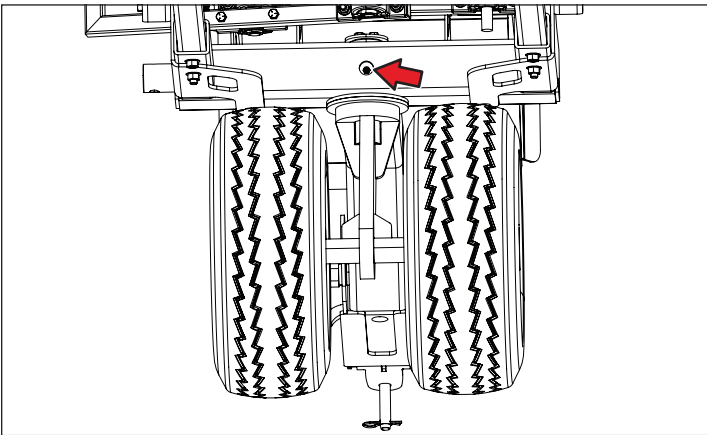

11.5 Wheel Bearing Adjustment

Check the wheel bearings for excessive end play annually. To adjust the wheel bearings:

- Remove the dust cap and cotter pin.
- Lift the tire and slowly rotate it while tightening the spindle nut.
- Tighten the spindle nut until a slight drag is felt on the rotating wheel.
- Re-install the dust cap and cotter pin.

11.6 Swivel Dolly Bushings

Check the swivel dolly for excessive play annually. If necessary, replace the non-metallic bushings.

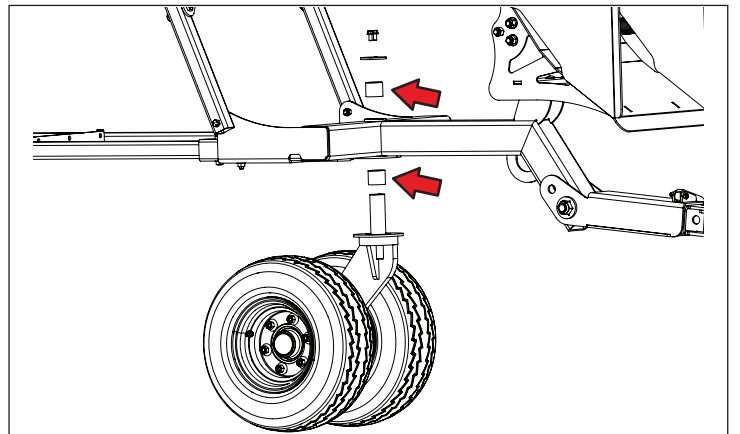

11.7 Tire Safety



Inflating or servicing tires can be dangerous. Whenever possible, trained personnel should be called to service and/or mount tires to prevent personal injury or death.

11.8 Tire Inflation

Check the tire pressure before each use. The recommended tire inflation pressure is 34 psi (235 kPa).

11.9 Bolt Torque Requirements

It is extremely important to apply and maintain proper torque on all bolts. Use a torque wrench to assure the proper amount of torque is being applied to the fastener.

Start all bolts or nuts by hand to prevent cross threading.

Torque figures indicated in the chart are used for non-greased or non-oiled threads, unless otherwise specified. Therefore, do not grease or oil bolts or cap screws unless otherwise specified in this manual. When using locking elements, increase torque values by 5%.

The chart gives correct torque values for various bolts and cap screws. Tighten all bolts to the torque specified in the chart, unless otherwise noted. Check the tightness of the bolts periodically, using the bolt torque chart as a guide. Always replace hardware with the same Grade bolt.

11.10 Standard Torque Values

Bolt Diameter	English Bolt Torque Specifications					
	Grade 5		Grade 8		ASTM A574	
	ft.lbs.	N·m	ft.lbs.	N·m	ft.lbs.	N·m
1/4"	9	12	12	17	14	18
5/16"	19	25	27	36	29	38
3/8"	33	45	45	63	51	69
7/16"	53	72	75	100	81	109
1/2"	80	110	115	155	124	168
9/16"	115	155	165	220		
5/8"	158	215	220	305	238	322
3/4"	290	390	398	540	423	573
7/8"	420	570	650	880	682	924
1"	630	850	970	1320	1022	1385

WARNING



Equipment Failure

The proper torque value for bolts and cap screws is identified by their head markings. Replacing higher "Grade" bolts (Grade 5) with lower Grade bolts will lead to equipment failure and could result in injury or death. Always use replacement bolts with the same Grade markings as the removed bolt.

11.11 Welding Repairs



Before performing any type of welding repair to the Hay Accumulator, contact Norden Mfg. for approval. Repair welding must be done with care and with procedures that may be beyond the capabilities of the ordinary welder.

WARNING

Personal Injury Hazard

Repairs or modifications to the unit may result in serious injury or death should these repairs fail.

NOTICE

Anyone performing a welding repair should be certified in accordance to the American Welding Society (AWS) standards.

11.12 Service Record

The period recommended is based on normal operating conditions. Severe or unusual conditions may require more frequent service.

Copy this page to continue record.

Hours and Serviced By													
Maintenance													
Daily													
Make sure the tires are inflated properly and the lug nuts are tight refer to "11.7 Tire Safety" on page 36.													
Make sure all retainer clips and pins are in place.													
Inspect the belted base chute and gates for wear and damage. Replace if necessary.													
Weekly													
Make sure all fasteners are tightened to proper torque. Refer to "11.10 Standard Torque Values" on page 36.													
Grease the wheel bearings. Refer to "11.4 Lubrication" on page 34.													
Annually													
Grease the belt tensioner bearings, end gate bearings, back shaft bearings, tongue pivot, and swivel dolly bushings. Refer to "11.4 Lubrication" on page 34.													
Inspect the wheel bearings for excessive end play. Refer to "11.5 Wheel Bearing Adjustment" on page 35.													
Make sure all fasteners are tightened to proper torque. Refer to "11.10 Standard Torque Values" on page 36.													
Check accumulator bed, gates, and linkage for damage.													
Inspect the belted base chute and tensioner for wear and damage.													
Make sure the hitch, hitch bolts, and hitch pin are in good condition. Do not use homemade or shop made pins.													
Wash the accumulator.													

12. Parts Section

12.1 Ordering Parts

Norden manufacture a quality product that requires very little maintenance or repair. However, should a part break or become damaged, our knowledgeable staff can make sure you receive the part(s) to put your unit back into operation.

12.2 Contact Information

For replacement decals, questions, or to order parts, contact:

Norden Mfg ,LLC
4210 Kinsman Road NW
North Bloomfield, OH 44450

Phone: 877-296-5851
Fax: 440-693-4336
E-mail: parts@nordenmfg.com

12.3 Decals



To prevent serious injury or death from not following posted safety instructions, make sure all decals are attached to the unit and are legible at all times.

Safety decals provide a vital role in helping to reduce injuries and/or possibly even death. To ensure the greatest level of safety, all decals must be in place and legible at all times. Remember, it is the users responsibility to maintain these decals.

All decals must be in place and legible or all warranties are void.

12.4 Hay Accumulator Undercarriage

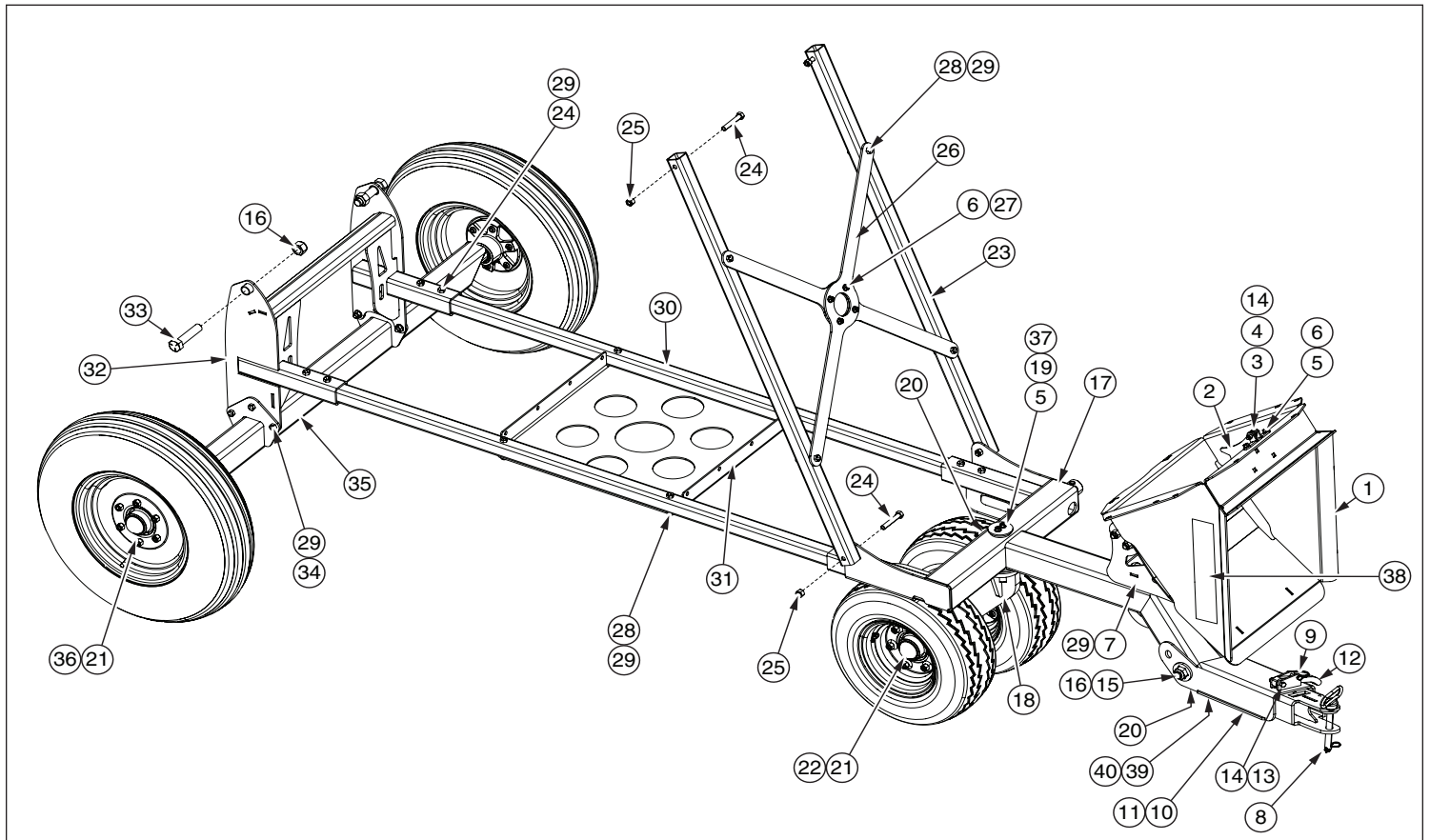

Item	Part Number	Description	Qty.
1	1000760	Weldment, Base Chute	1
2	1001911	Chute Dog	1
3	1001900	Bracket, Chute Dog	1
4	1006360	Bolt, Hex, 3/8 x 1-3/4" Grade 5	1
5	1006330	Bolt, Serrated Flange, 3/8 x 3/4" Grade 5	4
6	1006190	Nut, Serrated Flange, 3/8-16	6
7	1007520	Bolt, Carriage, 1/2 x 1" Grade 5	4
8	1007560	Pin, Hitch, 3/4" x 6"	1
9	1016540	Clevis Pin 1/4 X 1-3/4 Round	1
10	1000471	Tongue Base	1
11	1000461	Tongue Insert	1
12	1000480	Tongue Lock	1
13	1007550	Bolt, Hex, 3/8 x 2" Grade 5	1
14	1006090	Nut, Lock, Nylon, 3/8-16	2
15	1007450	Bolt, Hex, 1 x 6-1/2" Grade 5	1
16	1007500	Nut, Lock, Nylon, 1-8	3
17	1000923	Frame, Front	1
18	1000900	Weldment, Front Axle	1
19	1005230	Swivel Cap, Dual Dolly	1
20	1003730	Fitting, Grease (Not Shown)	2
21	1005200	Hub Assembly 888 AG Hub	2

Item	Part Number	Description	Qty.
22	1001010	Tire on Rim, 20.5x8 - 6 hole on 6 B.C.	2
	1003600	Wheel Rim, 10x6 - 6 hole x 6 B.C.	—
	1003570	Tire, 20.5x8-10	—
23	1001401	Pole, Upright	2
24	1006250	Bolt, Hex, 1/2 x 3" Grade 5	12
25	1006110	Nut, Lock, Nylon, 1/2-13	4
26	1000910	Cross, Front	2
27	1006340	Bolt, Serrated Flange, 3/8 x 1" Grade 5	4
28	1007580	Bolt, Hex, 1/2 x 2-3/4" Grade 5	8
29	1006210	Nut, Serrated Flange, 1/2-13	26
30	1001200	Pole, Reach	2
31	1001190	Connector, Reach Pole	1
32	1001270	Connector, Rear Axle	1
33	1007510	Bolt, Hex, 1 x 4-1/2" Grade 5	2
34	1006230	Bolt, Hex, 1/2 x 1-1/4" Grade 5	6
35	1001281	Axle, Rear	1
36	1001000	Tire on Rim, 9.5L-15 - 6 hole on 6 B.C.	2
	1003580	Tire, 9.5L-15	—
	1003610	Wheel Rim, 15x6 - 6 hole x 6 B.C.	—
37	1015930	Dolly Wheel Spring Bushing	2
38	1007980	Tape, Reflective, 2" H x 9", Amber	2
39	1000450	Stop, Tongue Insert	1
40	1007710	Bolt, Hex, 1 x 1-1/2" Grade 5	1

12.5 Hub Assembly

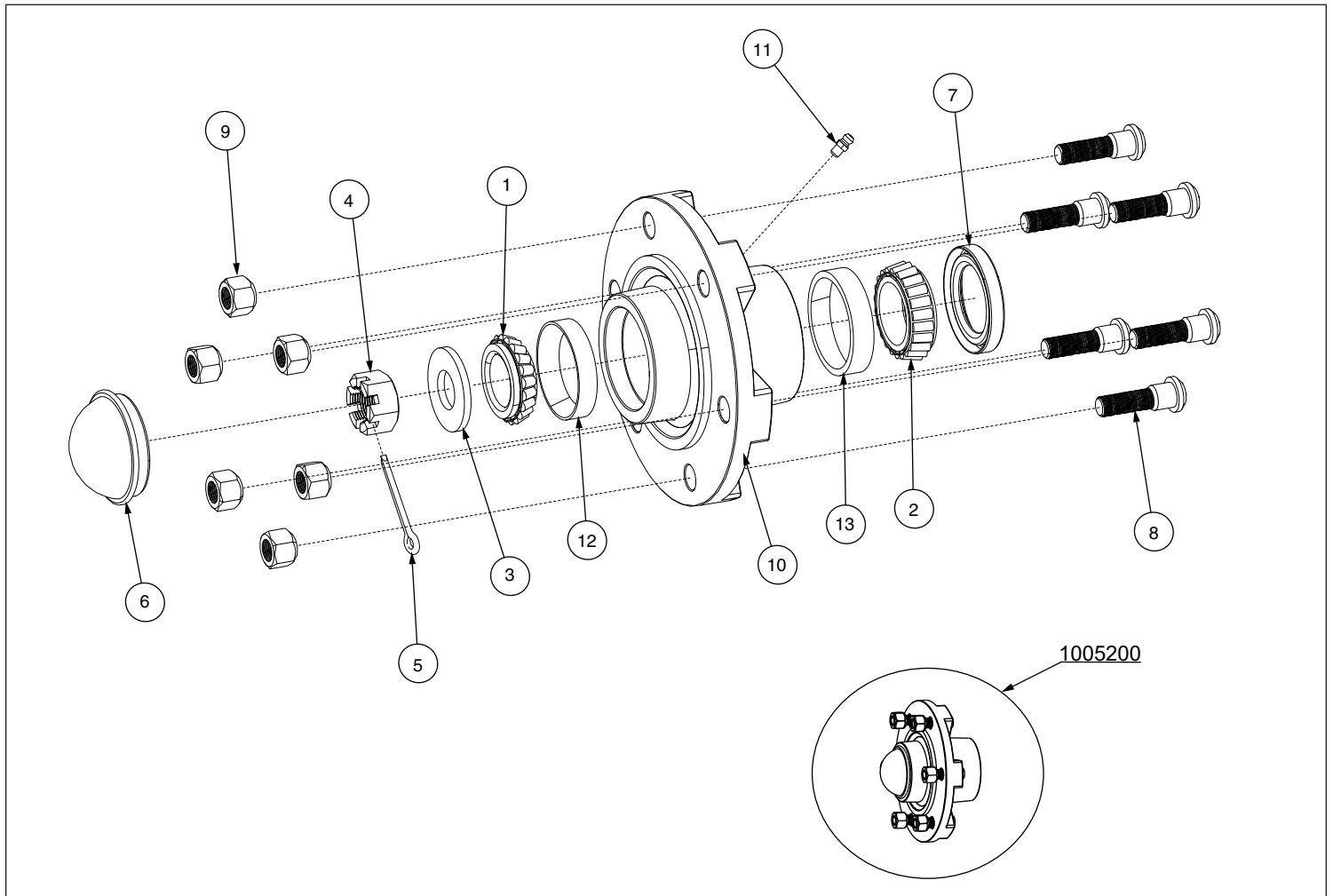

Item	Part Number	Description	Qty.
1	1003640	Wheel Hub Small (Outer Bearing) LM67048	1
2	1003630	Wheel Hub Large (Inner Bearing) JL69349	1
3	1003660	Wheel Hub Washer	1
4	1003700	Nut, Hex, Slotted, 7/8-14	1
5	1003720	Pin, Cotter, 1/8 x 1-1/2"	1
6	1003690	Wheel Hub Cap	1
7	1003710	Wheel Hub Rear Seal AG-GS-2566162 5SL	1
8	1003670	Wheel Hub Lug Bolt	6
9	1003680	Wheel Hub Lug Nut 1/2"- 20	6
10	1003650	Wheel Hub Frame, 888 6" Bolt Circle	1
11	1003730	Self Tapping Grease Zerk, 1/4	1
12	1005220	Small Bearing Race LM-67010	1
13	1005210	Large Bearing Race JL-69310	1
—	1009450	Service Kit, Includes items 1, 2, 3, 4, 5, 6, 7, 12, and 13	—

12.6 Accumulator Bed and Chute

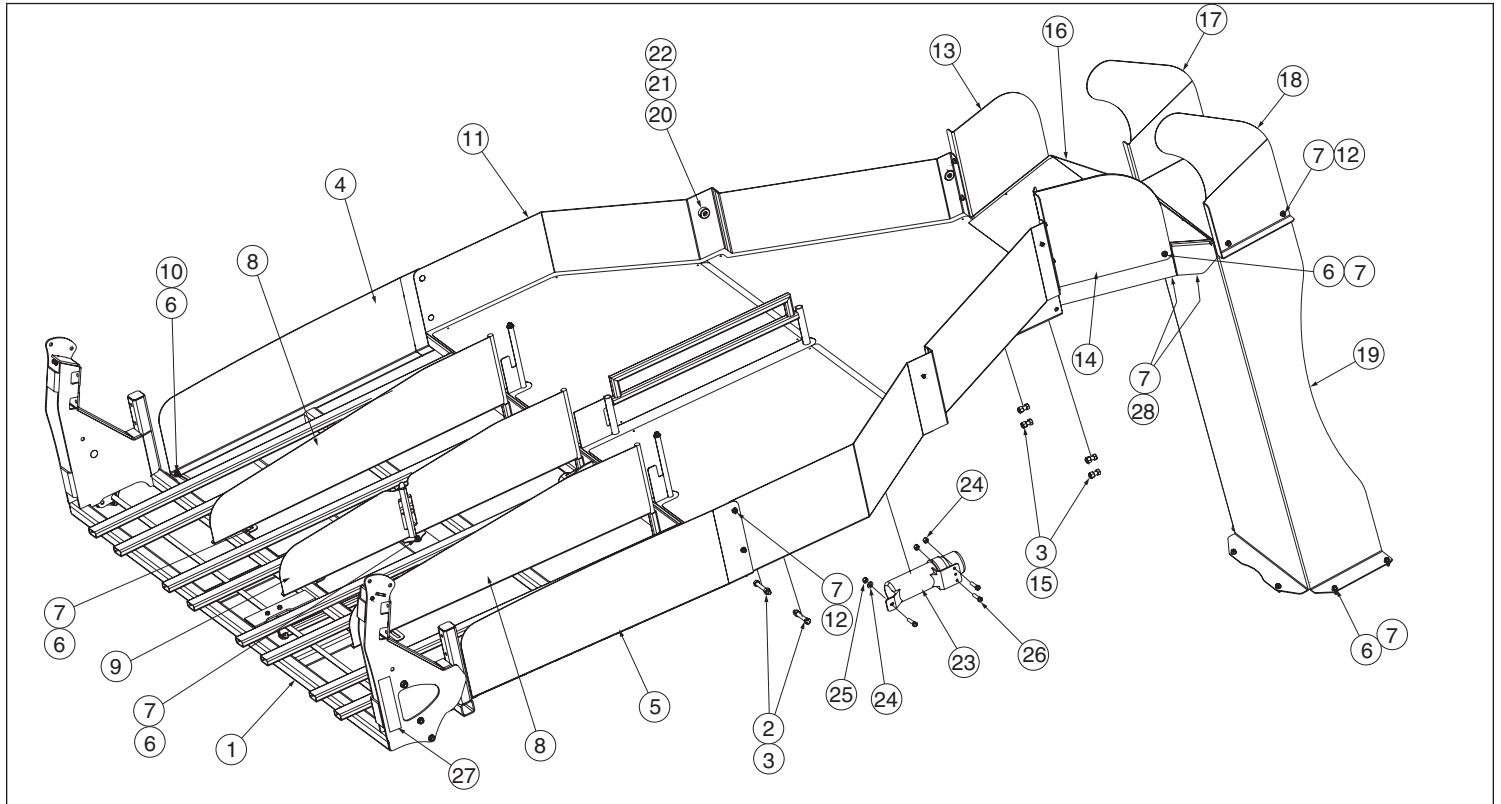

Item	Part Number	Description	Qty
1	1000693	Bed, Accumulator, Rear	1
2	1006250	Bolt, Hex, 1/2 x 3" Grade 5	2
3	1006210	Nut, Serrated Flange, 1/2-13	6
4	1001171	Panel, Outside, Left	1
5	1001181	Panel, Outside, Right	1
6	1006330	Bolt, Serrated Flange, 3/8 x 3/4" Grade 5	17
7	1006190	Nut, Serrated Flange, 3/8-16	30
8	1000850	Divider	2
9	1000861	Divider, with Switch	1
10	1006340	Bolt, Serrated Flange, 3/8 x 1" Grade 5	4
11	1001052	Platform, Gate	1
12	1006300	Bolt, Carriage, 3/8 x 3/4"	8
13	1000810	Side, Chute Platform, Left	1
14	1000820	Side, Chute Platform, Right	1
15	1006230	Bolt, Hex, 1/2 x 1-1/4" Grade 5	4
16	1000830	Platform, Chute	1
17	1000771	Extension, Chute, Flat Left	1
18	1000781	Extension, Chute, Flat Right	1
19	1001321	Chute, Straight	1
20	1003560	Bumper, Butyl Rubber	4
21	1006420	Bolt, Hex, 1/4 x 3/4" Grade 5	4
22	1006070	Nut, Lock, Nylon, 1/4-20	4
23	1006430	Document Canister	1
24	1006080	Nut, Lock, Nylon, 5/16-18	3
25	1006140	Washer, Flat, 5/16" SAE	1
26	1006290	Bolt, Hex, 5/16 x 1" Grade 5	3
27	1007980	Tape, Reflective, 2" H x 9", Amber	2
28	1006310	Bolt, Carriage, 3/8 x 1"	2

12.7 Linkage System

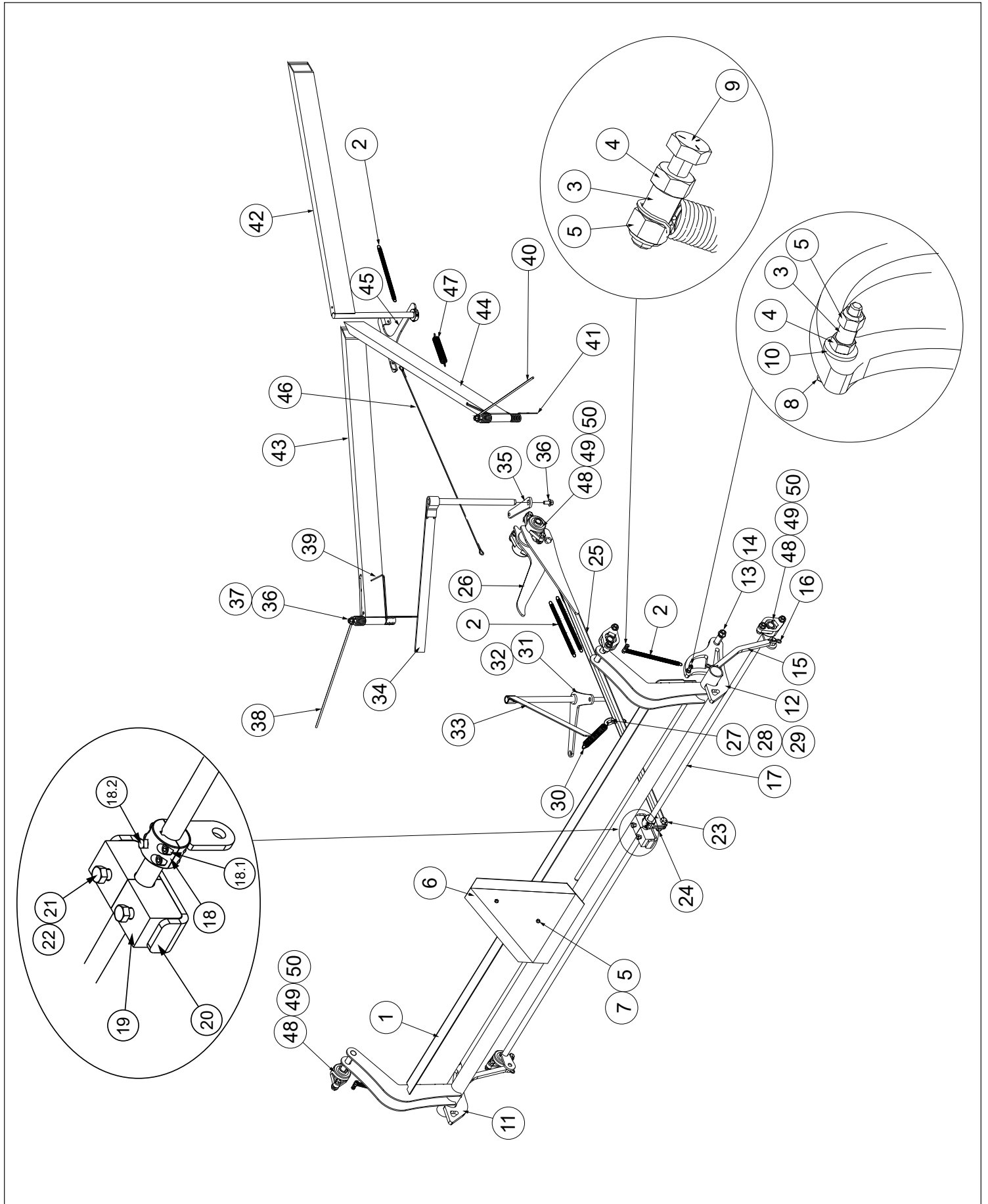

Item	Part Number	Description	Qty.
1	1000671	Back Gate	1
2	1005180	Spring, Return, 8-1/2"	5
3	1007600	Bushing, 3/8 OD x 5/16 ID, Brass	4
4	1007660	Nut, Hex, 1/4-20 Grade 5	4
5	1006070	Nut, Lock, Nylon, 1/4-20	6
6	1003750	SMV Sign	1
7	1006420	Bolt, Hex, 1/4 x 3/4" Grade 5	2
8	1007640	Bolt, Hex, 1/4 x 1-3/4" Grade 5	2
9	1007630	Bolt, Hex, 1/4 x 1-1/4" Grade 5	2
10	1006140	Washer, Flat, 5/16"	4
11	1000521	Hook, Back Gate, Left	1
12	1000531	Hook, Back Gate, Right	1
13	1007380	Bolt, Carriage, 1/2 x 3-1/4"	2
14	1006210	Nut, Serrated Flange, 1/2-13	2
15	1000602	Link, Trip, Back Gate	2
16	1008280	Pin, Cotter, 1/8 x 1-7/8"	4
17	1000561	Backshaft	1
18	1007161	Backshaft Ear	1
18.1	1016500	1/4-28 X 5/8 Zinc Plated Socket Head Cap Screw	4
18.2	1006870	Square Head Set Bolt 5/16"-18 X 1/2"	1
19	1000550	Brace, Backshaft, Half	2
20	1000541	Clip, Backshaft Brace	1
21	1006860	Bolt, Hex, 3/8 x 2-1/2" Grade 5	2
22	1006190	Nut, Serrated Flange, 3/8-16	2
23	1007650	Bolt, Hex, 1/2 x 1-3/4" Grade 5	1
24	1006110	Nut, Lock, Nylon, 1/2-13	1

Item	Part Number	Description	Qty.
25	1000611	Trip Reach, Back Gate	1
26	1001362	Trip Flipper, Back Gate	1
27	1007080	Eyebolt, 5/16 x 1-3/4"	1
28	1006600	Nut, Hex, 5/16-18 Grade 5	1
29	1006080	Nut, Lock, Nylon, 5/16-18	1
30	1007730	Spring, Extension, 6"	1
31	1000662	Trip Slider, Back Gate	1
32	1007610	Bolt, Hex, 5/16 x 1/2" Grade 5	1
33	1001041	Trip Switch	1
34	102250	Gate Switch SqHd, Flat Left	1
35	1022550	Switch Arm SqHd	1
36	1006330	Bolt, Serrated Flange, 3/8 x 3/4" Grade 5	2
37	1006160	Washer, Flat, 7/16"	2
38	1010250	Spring, Gate Actuating, Left	1
39	1005670	Spring, Gate Return, Left	1
40	1010260	Spring, Gate Actuating, Right	1
41	1005680	Spring, Gate Return, Right	1
42	1000950	Gate, Center	1
43	1035880	Gate, Flat Models, Outer Left	1
44	1035890	Gate, Flat Models, Outer Right	1
45	1007091	Arm, Gate	1
46	1007800	Cable Assembly, Center Gate	1
47	1005170	Spring, Center Gate, 12"	1
48	1003110	Bearing, Flange, 3/4"	6
49	1007270	Bolt, Hex, 7/16 x 1-1/4" Grade 5	12
50	1006200	Nut, Serrated Flange, 7/16-14	12

12.8 Belt and Tensioner

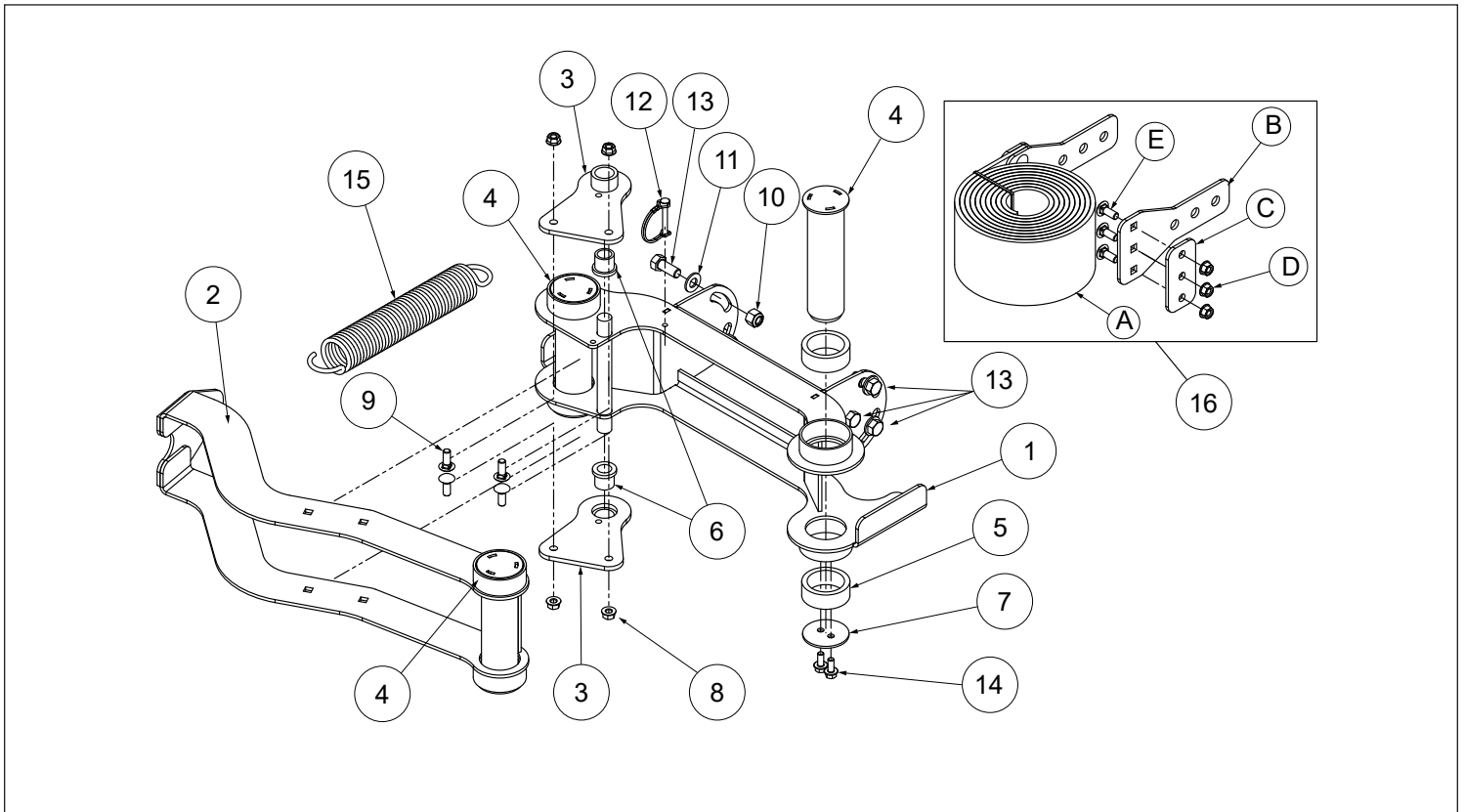

Item	Part number	Description	Qty
1	1021580	Roller Frame Weldment	1
2	1021590	Tensioner Frame Weldment	1
3	1021600	Tensioner Frame Bracket Weldment	2
4	1021570	Belt Roller Weldment	3
5	1021610	Roller UHMW Bushing	6
6	1021620	Roller Flange Bushing	2
7	1013790	Pivot Pin Washer	3
8	1006190	Hex Flange Nut 3/8-16	4
9	1006310	3/8-16 x 1" Carriage Bolt (Grade 5)	4
10	1006110	1/2" Nylock Nut	6
11	1006170	Type A flat washer 1/2	4
12	1016540	Clevis Pin 0.25 x 1.75 Round	1
13	1006230	Hex bolt 1/2-13 x 1.25	6
14	1024820	Hex flange bolt 5/16-18 x 0.75	6
15	1006590	BBC Spring	1
16	1016950	Belt with ends and hardware	1
A	1006750	BBC Rubber Belt, 12'	1
B	1006760	BBC Belt Large End Plate	2
C	1006770	BBC Belt Small End Plate	2
D	1006190	3/8" serrated flange nut	6
E	1006310	3/8-16 x 1" Carriage Bolt (Grade 5)	6

12.9 Bale Chamber Extension

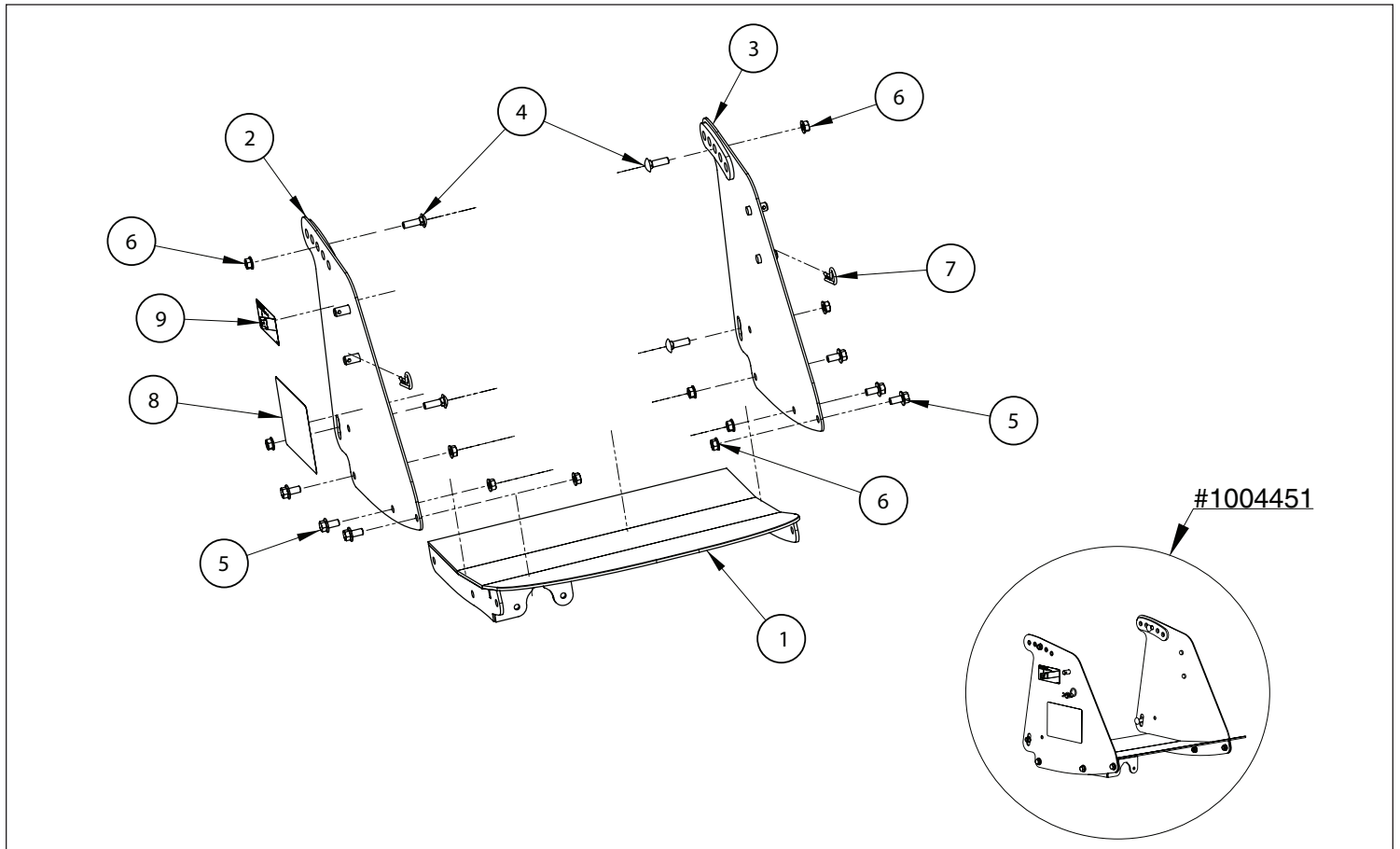

Item	Part Number	Description	Qty
1	1004421	Bottom, Chamber Extension	1
2	1004430	Side, Chamber Extension, Left	1
3	1004440	Side, Chamber Extension, Right	1
—	1004510	Chamber Extension Hardware Kit Items 4-7	—
4	1006320	Bolt, Carriage, 3/8" x 1-1/4", Grade 5	4
5	1006330	Bolt, Serrated Flange, 3/8" x 3/4", Grade 5	6
6	1006190	Nut, Serrated Flange, 3/8"-16	10
7	1006910	Cotter Pin 1/8" x 2.5"	2
8	1031230	Decal - Baler Set Up	2
9	1031220	Decal - Belt Cutting	1

12.10 Bale Roller

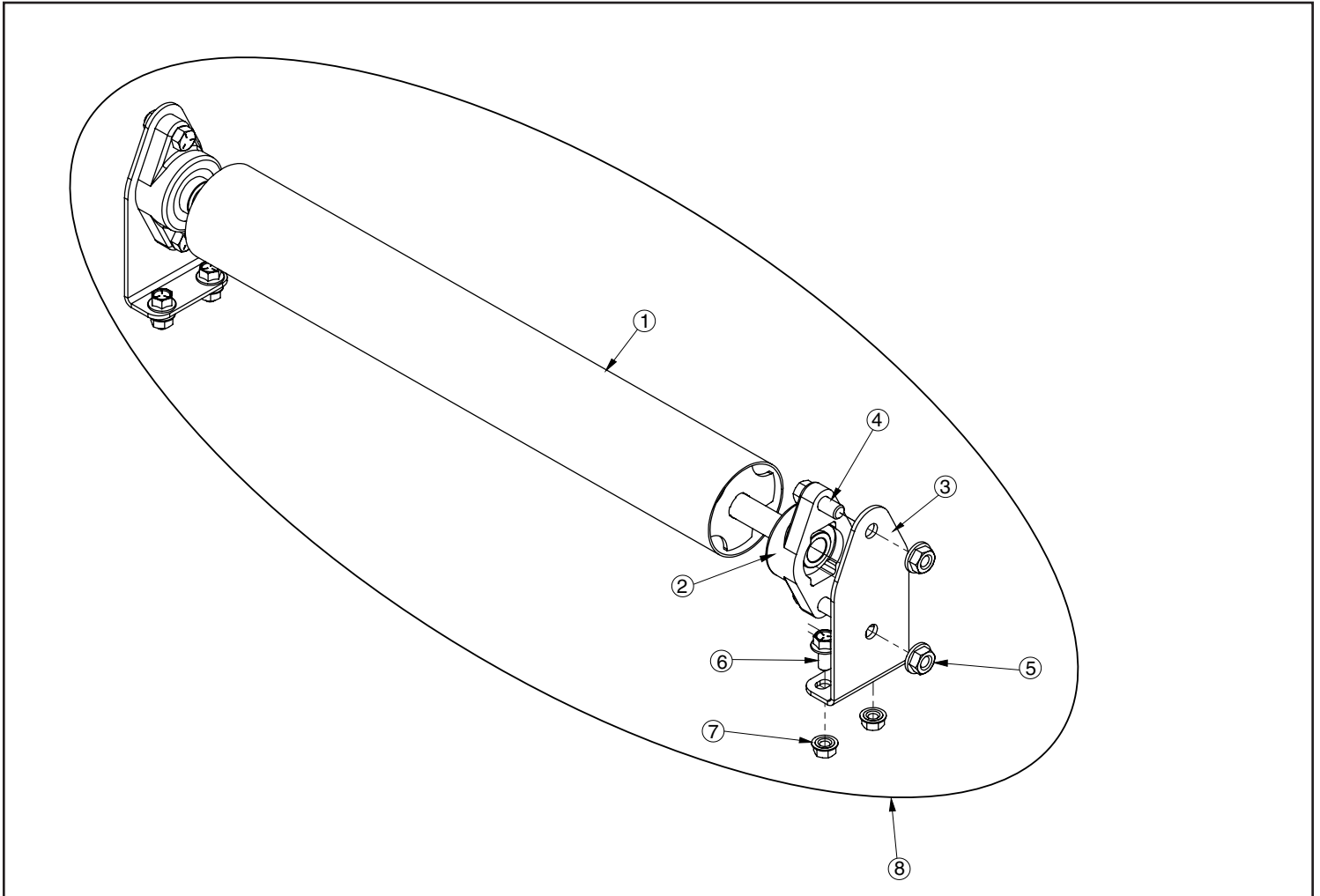

Item	Part Number	Description	Qty
1	1012570	Bale Roller	1
2	1003110	UCFT204-12 Flange Bearing	2
3	1012580	Bale Roller Stand	2
4	1007270	7/16"-14 x 1.25" Hex Bolt (Grade 5)	4
5	1006200	7/16"-14 Serrated Flange Nut (Grade 5)	4
6	1006330	3/8" 16 x 0.75 Serrated Flange Bolt	4
7	1006190	3/8" Serrated Flange Nut	4
8	1017300	Bale Roller Assembly	1

Bale Roller Assembly Kit available to order for older Accumulators
 "AE and "AF" models 2017-2019. Item #1017020

Refer to "12.1 Ordering Parts" on page 38

12.11 Lighting

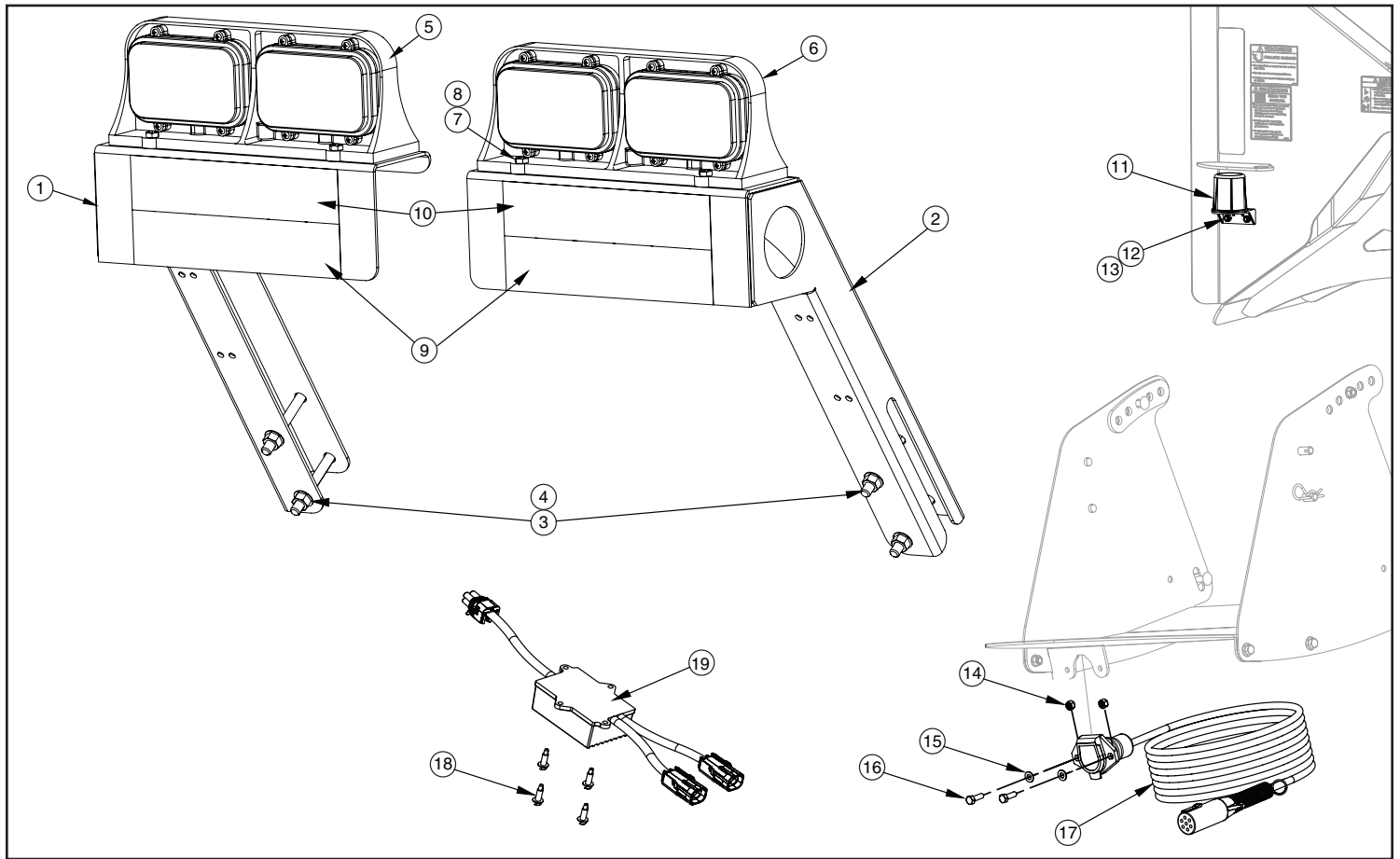

Item	Part Number	Description	Qty.
1	1001301	Bracket, Light, Left	1
2	1001311	Bracket, Light, Right	1
3	1006390	Bolt, Hex, 7/16 x 3", Grade 5	4
4	1006200	Nut, Serrated Flange, 7/16-14, Grade 5	4
5	1011040	Left Light, 4SQ	1
6	1011050	Right Light, 4SQ	1
7	1007620	Bolt, Hex, 1/4 x 1", Grade 5	8
8	1006070	Nut, Lock, Nylon, 1/4-20, Grade 5	8
9	1007990	Tape, Reflective, 2" H x 9", Red	2
10	1008000	Tape, Reflective, 2" H x 9", Orange	2
11	1010910	Lighting Plug Holder	1
12	1011120	Carriage Bolt 1/4"-20 x 3/4"	2
13	1006070	Nylock Nut 1/4"	2
14	1006080	Nylock Nut 5/16"	2
15	1006140	Type A Flat Washer 5/16"	2
16	1006290	Hex Bolt 5/16"-18 x 1"	2
17	1008021	Light Cable, 25' Baler Extension,	1
18	1007480	Driller Screw #12 x 7/8"	4
19	1011060	Lighting Module, Enhance 4SQ	1
	1011000	Left Cable, 4SQ, 71" (Not Shown)	1
	1011010	Right Cable, 4SQ, 91" (Not Shown)	1
	1011020	Main Cable, 4SQ, 18.5' (Not Shown)	1

12.12 Spring Kit

Kit Part #1016870

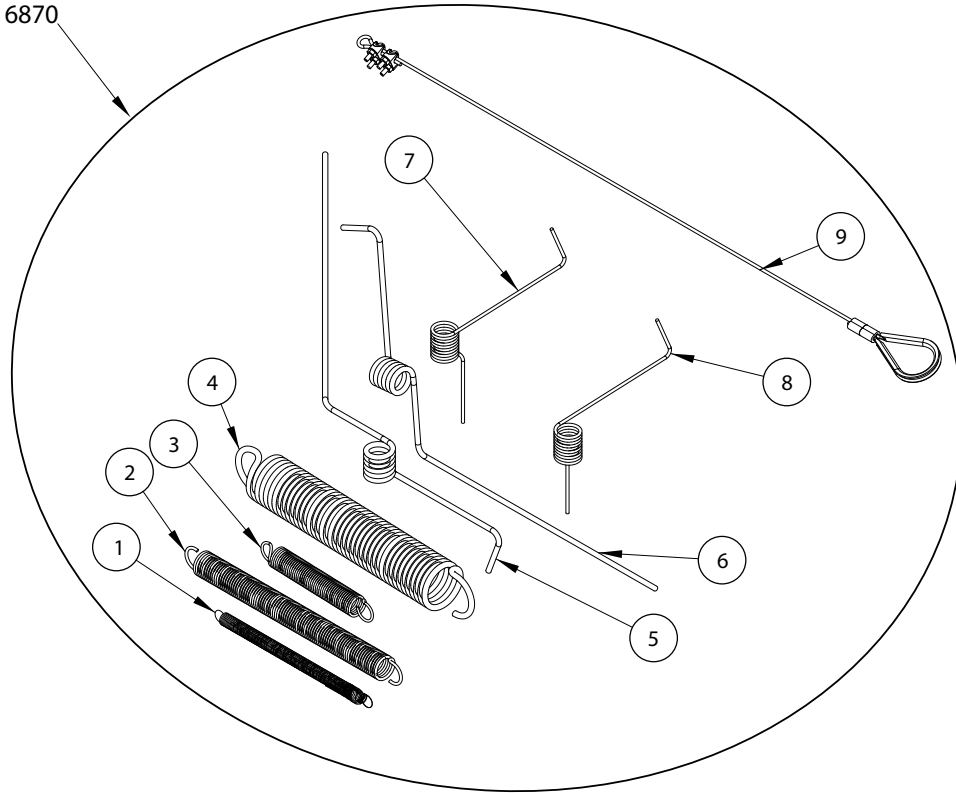

Item	Part Number	Description	Qty
1	1005180	8.5" Return Spring	5
2	1005170	12" Action Spring	1
3	1007730	6" spring	1
4	1006590	BBC spring	1
5	1010250	Gate Actuating Spring, Left	1
6	1010260	Gate Actuating Spring, Right	1
7	1005670	Gate Spring Return, Left	1
8	1005680	Gate Spring Return, Right	1
9	1007800	Cable Assembly for AF4, 4F, 5E, 5F gates and 6E lower gates	1

**NO
CONTENT**

**NO
CONTENT**

**NO
CONTENT**



Norden Mfg LLC
4210 Kinsman Road NW
North Bloomfield, OH 44450

(877) 296-5851
www.nordenmfg.com
support@nordenmfg.com

Norden Mfg is the successor to Kuhns Mfg  and all liability and warranty claims are transferable.

1008331 Rev B
Revised 08-2024