



NORDEN MFG

Owner's Manual

Tie Grabber Series



MADE IN THE USA 

Read, understand and follow the manual. This manual provides information and procedures to safely operate and maintain the Tie-Grabber.



CONTENTS

1. INTRODUCTION	4
1.1 Intended Usage	4
1.2 Operator Orientation.....	4
1.3 Warranty	4
1.4 Serial Number Location.....	4
1.5 Owner's Manual Storage.....	4
1.6 Specifications	5
1.7 Definitions.....	5
1.8 Product Improvements	5
1.9 Disposal of Equipment at End of Useful Life	5
1.10 .. Unanswered Questions	5
2. SAFETY	6
2.1 General.....	6
2.2 Safety Alert Symbols	6
2.3 Safety Icons Nomenclature	7
2.3.1.. Prohibited Actions	7
2.3.2.. Hazard Avoidance	7
2.4 General Operating Safety.....	8
2.5 Machine's Owner/Operator Manual.....	8
2.6 Machine's Safety Device Requirements.....	9
2.7 Practice Safe Maintenance	9
2.8 Training	9
2.9 Sign-Off Form.....	11
3. SAFETY SIGNS AND LOCATIONS	12
3.1 General Information.....	14
3.2 Safety Signs and Labels.....	14
3.3 Installing Replacement Safety Decals.....	14
4. LIFTING AND HANDLING	15
4.1 Lifting points	15
4.2 Transporting	15
4.3 Highway and Transport Operations.....	15
4.4 Pre-Transport Checklist.....	15
5. TIE GRABBER ATTACHMENT	16
5.1 Bracket Attachment	16
5.2 Hydraulic Safety	16
5.3 Hydraulic Connections	16
6. CONNECTING HOSES TO MACHINE	17
6.1 One Circuit System (Two Hose Method).....	17
6.2 Two Circuit System (Four Hose Method)	17
6.3 System Change Over	17
6.3.1.. Changing from One Circuit System to a Two Circuit System	17
6.3.2.. Changing from Two Circuit System to a One Circuit System	18
6.4 Crossover Relief Valve	19
6.5 Electrical Connections.....	19
7. THREADING TWINE INTO THE TWINE ARM	20
8. OPERATION	22
8.1 Operation Safety	22
8.2 Pre-Operation.....	22
8.3 Tie Grabber Operation	22
8.4 Normal Knotter Operation	24

9. MANIFOLD PORT LOCATIONS AND IDENTIFICATION	25
10. SETTING AND TIMING	28
10.1 .. Accessing the Knotter Components	28
10.2 .. Knife Arm.....	28
10.2.1 Adjusting the knife arm (3).	29
10.3 .. Testing and Adjusting Knotter Assembly	29
10.4 .. Twine Disc Assembly.....	31
10.5 .. Needle Position Within the Knotter.....	31
10.6 .. Cam Timing Mark	31
10.7 .. Tucker Finger	32
10.8 .. Knotter Drive Chain	32
10.9 .. Twine Arm Drive Chain.....	32
10.10 Twine Tensioner	32
11. MAINTENANCE	33
11.1 .. Maintenance Safety.....	33
11.2 .. Pre-Maintenance	34
11.3 .. Lubricating	34
11.3.1 Twine Arm	35
11.3.2 Squeeze Arm.....	35
11.3.3 Knotter Assembly	35
11.3.4 Chain Lubrication	36
11.3.5 Flow Control Valve Plunger.....	36
11.4 .. Hydraulic Hoses	36
11.5 .. Springs	36
12. MAINTENANCE SERVICE SCHEDULE SHEET	37
12.1 .. Torque Requirements	38
12.1.1 Bolt Torque Requirements Chart.....	38
12.1.2 Valve Torque Requirements	38
13. STORAGE	39
13.1 .. Placing in Storage	39
13.1.1 Removing from Storage	39
14. TROUBLESHOOTING	40
15. PARTS	43
15.1 .. Main Tie Grabber Assembly	43
15.3 ..43	
15.4 ..43	
15.5 ..43	
15.6 ..43	
15.7 ..43	
15.10 43	
15.9 ..43	
15.8 ..43	
15.2 .. Hooks	44
15.3 .. Squeeze Arm Assembly	45
15.4 .. Twine Arm Stack.....	46
15.5 .. Twine Arm Motor Group	47
15.6 .. Manifold Assembly	48
15.7 .. Twine Box Assembly, Crossover Relief Valve.....	49
15.8 .. Plunger Valve Assembly.....	50
15.9 .. Knotter Main Assembly.....	51
15.10 Knotter Motor Group.....	53

1. Introduction

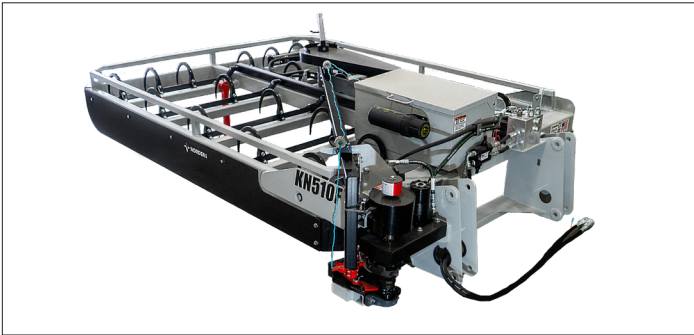

The Tie-Grabber automatically places twine around a group of bales that are deposited by the accumulator. Picking up a complete grouping of eight to eighteen bales of hay at one time allows wagons to be loaded more quickly as well as transported with more stability.

With a completely bundled grouping of hay bales, it also provides significant time savings as the need for load tie-downs is diminished to almost zero.

1.1 Intended Usage

Do not use this Tie-Grabber for any other purpose than its intended use of gathering groups of small square hay bales from a field, attaching the bales into a unit with twine and loading wagons.

1.2 Operator Orientation

The directions left, right, front, and rear, as mentioned throughout this manual, are as seen from the direction of travel.

NOTE: The specific term “Tie-Grabber” will be referred to simply as “unit” throughout the rest of this manual.

1.3 Warranty

Norden Mfg LLC Provides a warranty for 2 years from time of purchase against all Mfg defects and any normal wear.

All accidental breakage will be the responsibility of the customer to repair.

Norden Mfg LLC reserves the right to deny a warranty claim if machinery is used for anything other than its intended use.

All OEM parts are available from Norden Mfg LLC.

In the event of a warranty claim, Norden Mfg LLC may require the return of the defective or broken parts.

1.4 Serial Number Location

The Tie-Grabber’s serial number is located near the back right hand corner of the Tie-Grabber frame. Please use this number when requesting service, seeking information, or ordering parts. Record the serial number in the space provided for easy reference when contacting Norden Mfg LLC with questions.



Model _____

Serial Number _____

Date of Purchase _____

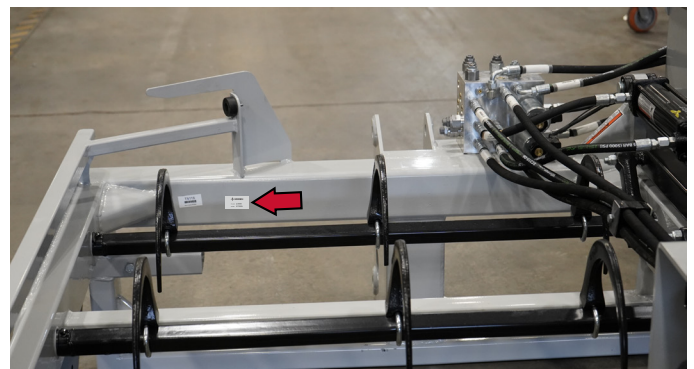

1.5 Owner’s Manual Storage

Store the owner’s manual and other operating materials in the document storage tube, located on the left side of the twine box.

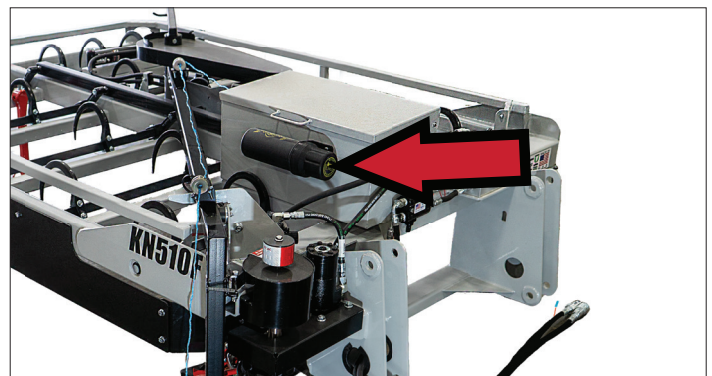

1.6 Specifications

The following chart lists the minimum lifting requirements of the loader used to operate the unit.



Tip Over Hazard



Using an under-rated machine can cause the machine to tip over, resulting in serious injury or even possible death. Attach the unit only to a machine with the proper lifting capacity.

Model Number	Minimum Machine Lifting Capacity in lbs*	Minimum Machine Lifting Capacity in kg*
KN408F	2000 lbs.	905 kg.
KN510	2100 lbs.	950 kg.
KN510F	2200 lbs.	1000 kg.
KN612F	2300 lbs.	1040 kg.
KN615	2500 lbs.	1134 kg.
KN615F	2600 lbs.	1180 kg.
KN615L	2600 lbs.	1180 kg.
KN618	2800 lbs.	1270 kg.
KN618L	2900 lbs.	1316 kg.

1.7 Definitions

Machine - Either a front end loader or a skid steer loader.

Unit - One of the available KN Series Tie-Grabber attachments.

1.8 Product Improvements

Because Norden Mfg LLC maintains an ongoing program of product improvement, we reserve the right to make improvements in design or changes in specifications without incurring any obligation to install them on units previously sold.

1.9 Disposal of Equipment at End of Useful Life

Norden Mfg LLC Tie-Grabber has been designed for specific purpose of arranging bales into groups. When this unit is no longer capable of performing its intended use, it should be dismantled and scrapped. Do not use any materials or components from this unit for any other purpose.

1.10 Unanswered Questions

If you have any questions not answered in this manual, require additional copies, or the manual is damaged, please contact your dealer, or :

Norden Mfg LLC
4210 Kinsman Road NW
North Bloomfield, OH 44450

Phone: 877-296-5851
Fax: 440-693-4336

E-mail: sales@nordenmfg.com

The manual is also available for download at:

www.nordenmfg.com

2. Safety

2.1 General

Most work related accidents are caused by failure to observe basic safety rules or precautions. An accident can often be avoided by recognizing potentially hazardous situations before an accident occurs. As you operate and maintain the unit, you must be alert to potential hazards. You should also have the necessary training, skills, and tools to perform any assembly or maintenance procedure.

WARNING

Improper operation and/or maintenance of this unit could cause a dangerous situation that results in injury or death.



Do not use the unit until you read and understand the information contained in this manual and all related equipment manuals.



Safety precautions and warnings are provided in this manual and on the unit. If these hazard warnings are not heeded, bodily injury or death could occur to you or to other persons.

Norden Mfg LLC cannot anticipate every possible circumstance that might involve a potential hazard. The warnings in this manual and on the product are therefore not all-inclusive. If a method of operation not specifically recommended by us is used, you must satisfy yourself that it is safe for you and for others. You should also ensure that the unit will not be damaged or be made unsafe by the methods that you choose.

The information, specifications, and illustrations in this manual are based on the information that was available at the time this material was written and can change at any time.

2.2 Safety Alert Symbols



This is the safety alert symbol. It is used to alert you to potential personal injury hazards. Obey all safety messages that follow this symbol to avoid possible injury or death.

This manual contains **DANGERS, WARNINGS, CAUTIONS, IMPORTANT NOTICES, and NOTES**, which must be followed to prevent the possibility of improper service, damage to the equipment, personal injury, or death. The following key words call the readers attention to potential hazards.

DANGER

Indicates an imminently hazardous situation which, if not avoided, will result in death or serious injury. This signal word is limited to the most extreme situations.

WARNING

Indicates a potentially hazardous situation which, if not avoided, could result in serious injury or death.

CAUTION

Indicates a potentially hazardous situation which, if not avoided, may result in minor or moderate injury.

NOTICE

Indicates that equipment or property damage can result if instructions are not followed.

SAFETY INSTRUCTIONS

Safety instructions (or equivalent) signs indicate specific safety-related instructions or procedures.

NOTE: Contains additional information important to a procedure.

2.3 Safety Icons Nomenclature













This manual and the equipment has numerous safety icons. These safety icons provide important operating instructions which alert you to potential personal injury hazards.

2.3.1 Prohibited Actions

-  Do not alter or modify
-  Do not weld
-  No riders
-  No children
-  No alcohol
-  No drugs

Personal Protection/Important Information

-  Read the manual
-  Maintenance procedure
-  Eye protection
-  Hearing protection
-  Hand protection
-  Foot protection
-  First aid kit
-  Fire extinguisher

-  Inspect equipment
-  Use proper tools
-  Place in neutral
-  Weight rating
-  Use OEM parts
-  Use ROPS and seat belt
-  Maintain safety signs
-  Place in park
-  Remove key
-  Stop engine
-  Visibility
-  Check/Maintain fluid levels
-  Set parking brake

2.3.2 Hazard Avoidance

-  Crushing hazard
-  Crushing hazard
-  Slipping hazard
-  Tripping hazard
-  Entanglement hazard
-  Hot surface

-  Fire hazard
-  Safety alert symbol
-  Zero pressure
-  Sharp object hazard
-  Defective or broken part
-  Maintain safe Distance
-  Pinch point hazard
-  Pinch point hazard
-  Pinch point hazard
-  Overturn hazard
-  Tip over hazard
-  Hose damage hazard
-  Explosive separation hazard
-  High pressure fluid hazard
-  Falling hazard

2.4 General Operating Safety

DANGER



Electrocution Hazard

Failure to comply with these instructions will result in death or serious injury.

Despite operating precautions, equipment can come in contact with electrical lines. It is important to know how to handle these situations.

If the machine comes in contact with overhead power lines, stay on the machine. Ask someone to contact the local utility company immediately to remove the danger. If there's an emergency, such as an electrical fire, and you need to leave the equipment, jump as far away from the equipment as possible. Do not allow any part of your body to touch the equipment and the ground at the same time.

Once you get away from the equipment, never attempt to get back on or even touch the equipment. Many electrocutions occur when the operator dismounts and, realizing nothing has happened, tries to get back on the equipment.

WARNING

Failure to comply to these safety instructions could result in serious injury or death.

Read, Understand, and Follow the Manual



To prevent personal injury or even death, be sure you read, understand and follow all of the instructions in this manual and other related OEM equipment manuals! This unit was designed for a specific application; **DO NOT** modify or use this unit for any application other than which it was designed. Units operated improperly or by untrained personnel can be dangerous! Inexperienced operators should receive instruction from someone familiar with the equipment before being allowed to operate the unit.

Do Not Operate



Do not use the unit if it is in need of repair. If you believe the unit has a defect which could cause injury or death, you should immediately stop using the unit.

Fall Hazard



Do not use the unit as a platform. Do not stand on top of the unit at any time. Do not ride on the unit or allow others to ride on it.

Impaired User Hazard



Do not attempt to assemble, operate, or maintain the unit under the influence of drugs or alcohol. Consult your doctor before using the unit while taking prescription medications.

Entanglement Hazard



Keep hands, feet, clothing, jewelry, and long hair away from any moving parts to prevent them from getting caught.

Crush Hazard



DO NOT GO UNDER THE UNIT FOR ANY REASON

Stay Clear



Clear the area of people, especially small children, before using the unit. Under no circumstances should young children be allowed to work with or around the unit.

2.5 Machine's Owner/Operator Manual



Always refer to and be familiar with the machine's owner's manual to ensure compatibility and maximum safety.

Refer to the Machine's Operator' Manual to make sure the machine use meets the minimum lifting capacity requirements for your unit. Refer to "1.6 Specifications" on page 5.

Operating the unit with a machine that does not meet the following requirements may cause damage to the unit and /or the machine and can be a danger to the operator and passerby.

Always review the "controls" section of the machine's operator's manual to be familiar with the location, settings, and function of the controls. Be familiar with all controls before using this unit.

2.6 Machine's Safety Device Requirements

Approved Roll-Over Protective Structure (ROPS) or ROPS cab and seat belt.

Machine Safety Devices; Slow Moving Vehicle (SMV) emblem, lighting, PTO master shield.

To reduce the risk of fire, do not use a machine with an under-frame exhaust.

WARNING

Rollover Hazard



To avoid serious injury or death from falling off the machine, equipment run over, rollover, or crushing: Use ROPS equipped machines.

Keep ROPS locked in the UP position.

Only operate the equipment when seated in the operators seat.

Always fasten seat belt when operating the machine.

Use caution when transporting over uneven terrain and slow down for turns.

The machine must be equipped with a roll over protective structure (ROPS) (cab or roll bar) and seat belt to protect the operator from falling off the machine, especially during a roll-over where the driver could be crushed and killed. Only operate a machine with the ROPS in the raised position and seat belt fastened.

2.7 Practice Safe Maintenance

SAFETY INSTRUCTIONS



Understand service procedures before doing any work. Keep the work area clean and dry.



Keep all parts in good working condition and properly installed. Replace worn or broken parts immediately.



Do not modify the unit or its safety devices. Do not weld on the unit. Unauthorized modifications may impair its function and safety.

2.8 Training

Anyone who will be using and/or maintaining the unit must read, clearly understand, and follow ALL safety, operation, and maintenance information presented in this manual, other related OEM manuals, and the safety signs.

If you do not understand any information in this manual, see your dealer or contact Norden Mfg LLC before proceeding.

Do not use or allow anyone else to use this unit until all information has been reviewed. Annually review this manual before the season start-up.

SAFETY INSTRUCTIONS

Make periodic reviews of SAFETY and OPERATION a standard practice. An untrained operator is not qualified to use this unit.

Norden Mfg LLC follows the general Safety Standards specified by the Farm Equipment Manufacturers Association (F.E.M.A.), and the American National Standards Institute (ANSI). Anyone who will be using and/or maintaining the unit must read and clearly understand ALL safety, operation and maintenance information presented in this manual.

See "2.9 Sign-Off Form" on page 11

WARNING

Failure to comply to these safety instructions could result in serious injury or death.

Roll Away Hazard



The weight of the machine, plus the unit, if it rolls onto a person, could cause serious crushing injury or death.

Crush Hazard



The machine should be equipped with a roll over protective structure (ROPS) and a seat belt. A crushing hazard could occur if the operator is ejected from the seat while the machine is in motion. Fasten the seat belt whenever the machine is moving.

Entanglement Hazard



Keep hands, feet hair, and clothing away from rotating parts. Do not clean, lubricate, or adjust your unit or machine while it is moving.

SAFETY INSTRUCTIONS

Failure to follow these safety instructions could result in injury and equipment damage.

Train Unfamiliar Users



It is the owner's responsibility to make sure any person using the unit, especially if it is loaned or rented, has been thoroughly trained on its proper and safe use.

Be certain only physically-able persons will use the unit.

Users who have not read and understood all operating and safety instructions are not qualified to use the unit.

Never allow children to operate equipment.

Operation Safety

Refer to "8.1 Operation Safety" on page 22 for safety recommendations related to maintaining the unit. All applicable safety recommendations in other sections should also be followed.

Maintenance Safety

Refer to "11.1 Maintenance Safety" on page 33 for safety recommendations related to maintaining the unit. All applicable safety recommendations in other sections should also be followed.

Storage Safety

Refer to "13.1 Placing in Storage" on page 39 for safety recommendations related to storing the unit. All applicable safety recommendations in other sections should also be followed.

Hydraulic Safety

Refer to "5.2 Hydraulic Safety" on page 16 for safety recommendations related to general hydraulics. All applicable safety recommendations in other sections should also be followed.

Transporting Safety

Refer "4.2 Transporting" on page 15 to for safety recommendations related to transporting the unit. All applicable safety recommendations in other sections should also be followed.

2.9 Sign-Off Form

This sign-off sheet is provided for your records to show that all personnel who will be working with the equipment have read and understand the information in this operation and parts manual and have been instructed in the operation of the equipment.

Sign-Off Form		
Date	User's Signature	Owner's Signature

3. Safety Signs and Locations

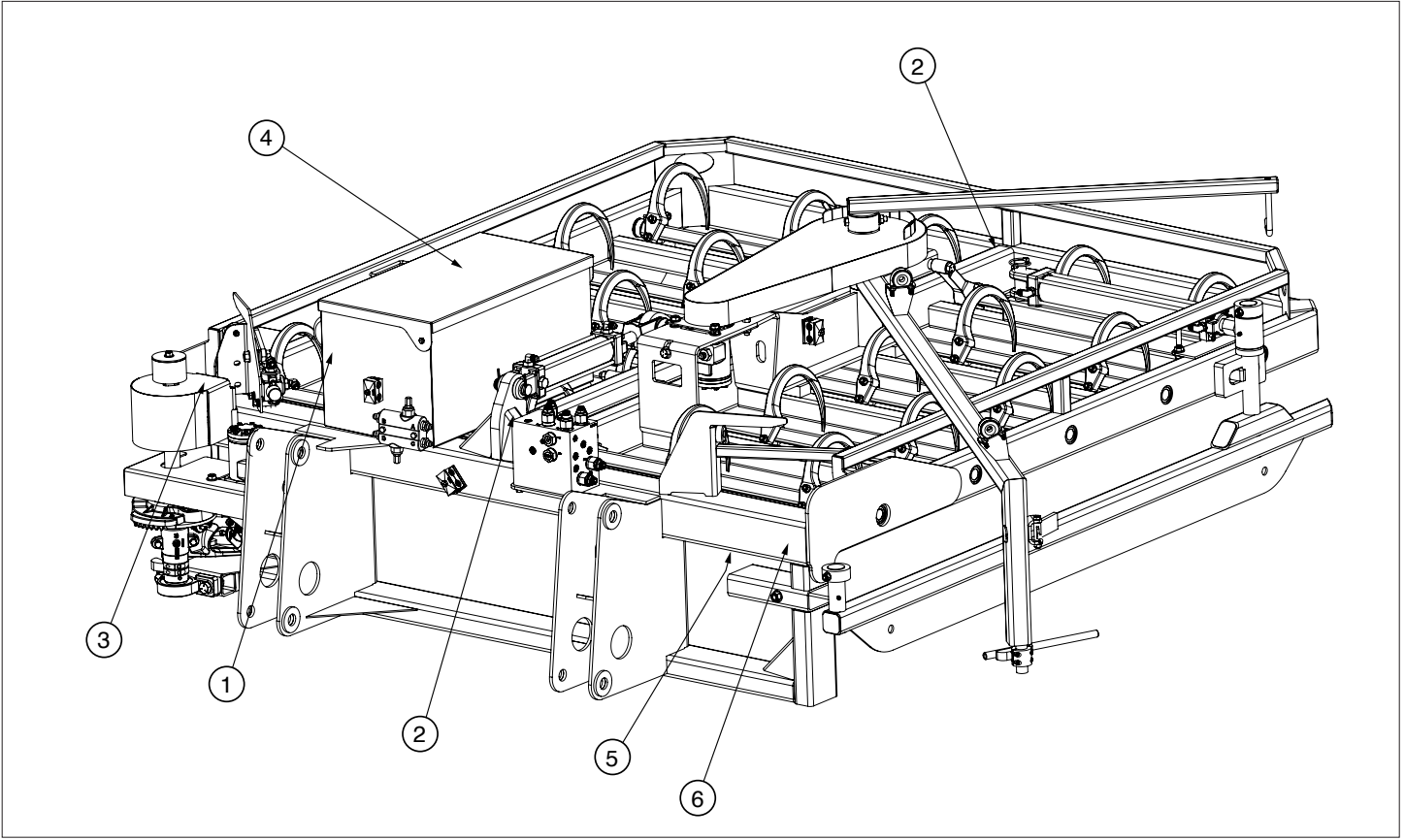

Item	Type	Description	Qty
1	WARNING	Read the manual	1
2	WARNING	No riders	2
3	DANGER	Pinch point	1
4	CAUTION	Twine threading instructions	1
5	INFORMATIONAL	Serial number	1
6	INFORMATIONAL	Made in the USA	1

1. Warning—1030130 Read Manual

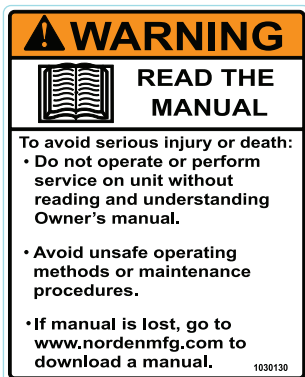

5. Informational— Serial Number

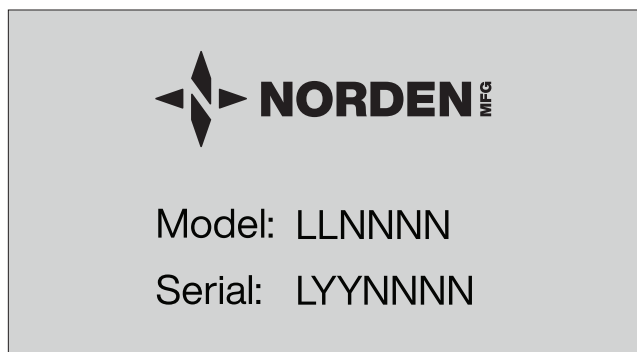

2. Warning— 1029530 No Rider



6. Informational— 1024360 Manufacturer Placard

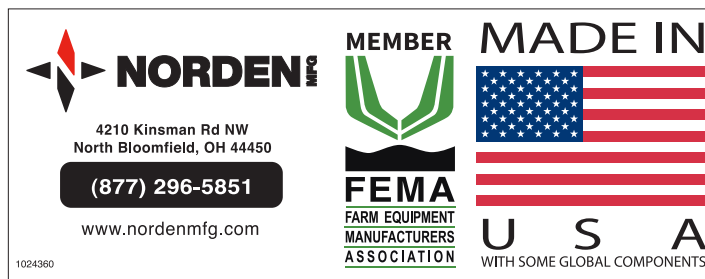

3. Danger— 1030230 Pinch Point



4. Caution— 1030240 Twine Threading Instructions

Twine Threading Instructions

170 - 210 rated knot strength plastic twine is recommended for use with the Tie-Grabber

1. Rotate arm to approximately 2-3 feet from knotter
2. Bring twine out of the box through insulator
3. Through insulator, from middle of grabber toward the outside
4. Through insulator on end
5. Through needle
6. Tie off to 2x2 cross member
7. Rotate arm into knotter and hold until the knotter cycle is complete
8. Return arm to opposite side
9. Remove remnant twine from 2x2

CAUTION

CRUSHING HAZARD
Do not stand near the unit when the twine arm is in motion. Contact with the twine arm while it is rotating can cause serious injury. Keep all children and bystanders away from unit while it is operating.

CAUTION

CRUSHING HAZARD
Stop the machine on flat ground before leaving the machine and/or continuing the twine threading operation, always make sure the machine's engine is stopped, the ignition key is removed, all controls are placed in neutral, the parking brake is set, and all hydraulic fluid pressure is relieved (zero pressure). Failure to follow these instructions can result in serious injury.

1030240

3.1 General Information

The types of safety signs (hazard labels) and instructional labels, along with their locations on the equipment, are shown in the previous illustrations. Good safety practices require that you familiarize yourself with the various safety signs, the type of warning, and the area or particular operation related to that area that requires your SAFETY AWARENESS.

Pay close attention to the safety signs and instructional labels attached to the machine and unit. If the unit is missing a label or one is unreadable, replace the label before using the unit.

3.2 Safety Signs and Labels



Legible Safety Decals

 **Keep Safety decals clean and legible at all times. Replace any safety decal or instruction sign that is missing or not legible.**

Replacement parts that displayed a safety decal should also display the current sign. Replacement safety decals are available from your authorized dealer or factory at no cost.



Safety and Instructional Decals

Keep safety decals or instructional decals clean and legible at all times. Use a clean, damp cloth to clean safety decals.

1. Replace and missing or hard-to-read safety signs or instructional decals.
2. Use care when washing or cleaning the equipment. Make sure not to remove or damage the labels. When using a pressure washer to clean the unit, avoid spraying too close to decals; high-pressure water can enter through very small scratches or under edges of decals causing them to peel or come off.
3. Locations for the decals and replacement part numbers are shown in this section.

4. Replacement parts must have correct replacement decals attached before the unit is used.
5. Decals are available from your authorized dealer or from Norden Mfg LLC at no charge.

For replacement decals, contact:

Norden Mfg LLC
4210 Kinsman Road NW
North Bloomfield, OH 44450

Phone: 877-296-5851

Fax: 440-693-4336

E-mail: parts@nordenmfg.com

3.3 Installing Replacement Safety Decals

1. Clean and dry the installation area.

NOTE: Do not install the decal if the temperature is below 50°F.

2. Determine the exact position for the decals before removing the backing paper.
3. Remove the backing paper.
4. Align the decal over the specified area and carefully press the sign to the part/frame.

NOTE: Small air pockets can be pierced with a pin and smoothed out using the piece of backing paper.

4. Lifting and Handling

4.1 Lifting points

Should the unit need to be moved by a fork truck, the forks on the fork type truck being used should be between 48 - 60 inches in length. The fork type truck must have the lifting capacity required by the unit being moved.

WARNING

Tip Over Hazard



Using an under-rated machine can cause the machine to tip over, resulting in serious injury or even possible death.

4.2 Transporting

SAFETY INSTRUCTIONS



Before transporting make sure the tractor or loader used is in the good operating condition according to the OEM user's manual.



When transporting the unit on a roadway, make sure that the tractor or loader has a clearly visible SMV placard.



Make sure that the area is clear of children, animals, people and other obstacles before moving the unit. This is particularly important with higher noise levels and quiet cabs as you may not hear people shouting.



Do not allow anyone to ride on the tractor or the unit.

4.3 Highway and Transport Operations

SAFETY INSTRUCTIONS

Always drive at a safe speed relative to conditions and ensure that your speed is low enough for an emergency stop to be safe and secure. Keep speed to a minimum.

- Reduce speed prior to turns to avoid the risk of overturning
- Always keep the tractor or loader in gear to provide engine braking when going downhill. Do not coast.

- Make sure when transporting with a truck or trailer to secure the unit to the transport and to move the jack stand to the weight bearing position.
- Use approved accessories lighting, flags, or other necessary warning devices to protect operators of other vehicles on the highway during daylight and nighttime transport. Various safety lights and devices are available from your dealer.
- Be a safe and courteous driver. Always yield to oncoming traffic in all situation, including narrow bridges, intersections, etc. Plan your route to avoid heavy traffic.
- Watch for overhead obstructions and side clearances while transporting.
- Always operate equipment in a position to provide maximum visibility at all times. Make allowances for increased operating length and weight, when making turns, stopping, etc.

4.4 Pre-Transport Checklist

✓	Task
	Before transporting, make sure the maintenance on the tractor or loader are current.
	Check the tire pressures on the tractor or loader and correct if necessary.
	Make sure the unit is securely attached to the tractor or loader. Always inspect the unit and the bracket for damage, abnormal wear, or excessive wear when hooking up.
	Prior to transporting on a roadway, have an observer confirm that all running lights, brake lights, turn signals, and hazard lights are working.
	Verify the brakes operate correctly.

5. Tie Grabber Attachment

This section of the manual will go over attaching the unit to a front end loader or a skid steer loader.

The units include a loader mounting bracket of your choice.

Follow the OEM machine manufacturer's recommendations for attaching the machine to the Tie Grabber attachment.

Attachment brackets are bolted on and will allow the end user to use the same unit with various machines. The bolt-on brackets are factory installed according to the sales order.

5.1 Bracket Attachment

NOTICE

Always be sure that the bolts between the unit and the mounting bracket are in place, tight, and in good condition.

When connecting from the mounting bracket to the tracker or loader follow the instructions and safety steps called for by your machine's manual.

5.2 Hydraulic Safety

WARNING

High-Pressure Fluid Hazard



Hydraulic fluid escaping under pressure can penetrate the skin. Openings in the skin and minor cuts are susceptible to injection from hydraulic fluid. If injured by a concentrated high-pressure stream of hydraulic fluid, seek medical attention immediately. Without immediate medical treatment, serious infection or toxic reaction can develop if hydraulic fluid penetrates the surface of the skin.

Hose Damage Hazard



Before applying pressure to the system, make sure all components are tight and that the hydraulic lines hoses, and couplings are not damaged. Replace any worn, cut, abraded, flattened, or crimped hoses.

Personal Protective Equipment



Wear proper hand and eye protection when searching for a high-pressure hydraulic leak. Use a piece of wood or cardboard as a backstop instead of hands to identify and isolate a leak.

Trapped Air Hazard



When installing, replacing, or repairing hydraulic system cylinders or parts, make sure that the entire system is charged and free of air before resuming operations. This can be done by cycling the unit a few times before starting to use the unit.

Explosive Separation Hazard



Do not make any temporary repairs to the hydraulic lines, fittings, or hoses using tape, clamps, or adhesives. The hydraulic system operates under extremely high pressure and temporary repairs may fail suddenly and create a hazardous/dangerous situation.

NOTICE

Make sure components in the hydraulic system are kept clean and in good working condition

The Most common reason for hydraulic component failure is contamination of the oil. Keep all hydraulic access areas completely clean, such as around the hydraulic oil filler cap, filter, and connection points. Replace any fittings, hoses or other components where leakage is observed. Clean up any spilled hydraulic oil.

5.3 Hydraulic Connections

The unit can work with either a two circuit system (four separate hydraulic hose connections) or a one circuit system (two separate hydraulic hose connections). In the following sections we will walk through both setups. Your machine will need a hydraulic system that meets these minimum requirements: Minimum PSI of 2000 and Minimum Flow of 5 gallons per minute.

NOTE: If using the one circuit setup, (typically Factory installed), the machine will need a 12 volt power source to run the solenoids in the manifold.

Refer to "6.5 Electrical Connections" on page 19 for information on adapters.

6. Connecting Hoses to Machine

6.1 One Circuit System (Two Hose Method)

Connect the lines from the Crossover Relief Valve (bolted on the twine box) connected to Port F and Port E into one circuit on the machine using 7 pin, 8 pin, or 14 pin adapter.

Use the following instructions when using the Splitter Handle option. (Shipped inside the Twine Box)

1. Mount the provided splitter handle (found inside the Twine Box) in the cab of the machine.



2. Next route and secure the long wire from the splitter handle out of the cab along the bucket arm and connect it to the short wire coming out of the unit.

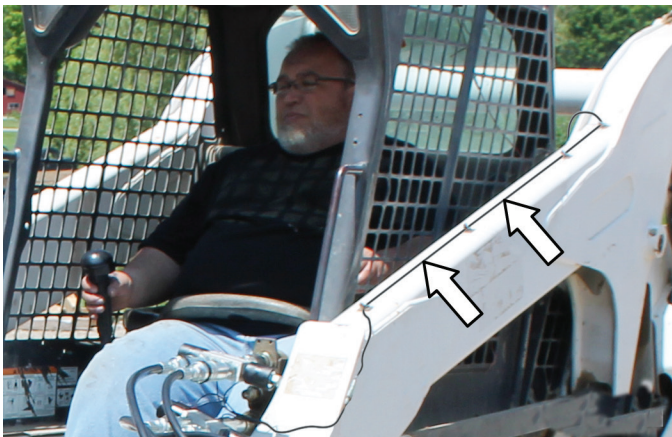

3. Connect the red wire on the splitter handle to a 12 volt power source.

NOTE: You should install an in-line fuse between the power source and the splitter handle.

NOTICE

To Prevent damage, route the wire in such a manner that it will not be damaged when the lift arms of the machine raise or lower the unit.

NOTE: The connection of the hoses to the machine dictates the operation of the unit. For example, if the twine arm moves forward when the machine's control is pulled back, reversing the hoses will make the twine arm operate in reverse. The operating direction of the machine's controls should be set to the end user's preference.

CAUTION

 **Check the machine's hydraulic reservoir, after connecting and cycling the unit, for proper fluid level. Operating the machine without the proper oil level can cause damage to both the unit and the machine.**

6.2 Two Circuit System (Four Hose Method)

With a four hose system there is no need for solenoids on the unit because the system has two circuits. A Tie-Grabber can be ordered with the 4 hose system factory installed.

1. Connect the lines from Port A and Port B into one circuit on the machine.
2. Connect the lines from Port C and Port D into a different circuit on the machine.

NOTE: Crossover Relief Valve is not needed with Two Circuit System.

6.3 System Change Over

If at any point the user wishes to change from one system to the other, Norden Mfg LLC should be contacted to supply the OEM part. Once you have parts, steps in this section can be followed. This section only pertains to manifolds produced in 2017 and later.

6.3.1 Changing from One Circuit System to a Two Circuit System

WARNING

 **Before disconnecting any hydraulic hoses or fittings on or from the unit make sure the hydraulic fluid pressure is relieved to zero pressure. Failure to follow this safety instruction can result in serious injury and possible death.**



OEM Parts for a Two Circuit System Change Over

1. Disconnect the unit from the machine and relieve any hydraulic pressure in the unit.
2. Place an oil pan below the manifold area. At the manifold remove the hoses and adapters from Port F and Port E. (Crossover Relief Valve will not be needed in Two Circuit System).
3. Remove the plugs from Port A, Port B, Port C, and Port D.
4. Use two of the plugs you removed in step 3 to plug Port E and Port F.
5. Remove the solenoid wire from the unit.
6. Remove the two Solenoids from Port SV3 and Port SV4, and replace with OEM cavity plugs, PN 1017550.
7. Using the adapters, PN 1009690, connect hoses to the following ports: Port A, Port B, Port C, and Port D.
8. Reconnect the unit to the machine.

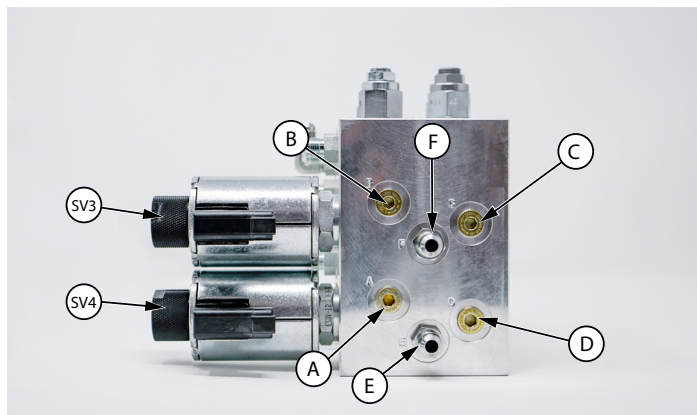

6.3.2 Changing from Two Circuit System to a One Circuit System

WARNING

Before disconnecting any hydraulic hoses or fittings on or from the unit make sure the hydraulic fluid pressure is relieved to zero pressure. Failure to follow this safety instruction can result in serious injury and possible death.



NOTE: Manifolds produced after 2017

OEM Parts for Two Hose Change Over

1. Disconnect the unit from the machine and relieve any hydraulic pressure in the unit.
2. Place an oil pan below the manifold area. At the manifold remove the hoses from Port A, Port B, Port C, and Port D.
3. Remove the plugs from Port E, Port F, Port SV3, and Port SV4.
4. Install an OEM Solenoid in each of the following Ports; Port SV3 and Port SV4. Install the OEM plugs in each of the following ports: Port A, Port B, Port C, and Port D.
5. Connect hoses from the Crossover Relief Valve to Port E and Port F.
6. Using the OEM Wire Harness, snap the connectors into each of the solenoids.
7. Ground the ring terminal to the frame using one of the manifold mounting bolts.
8. Mount the handle onto the machine.
9. Reconnect the unit to the machine.

NOTE: Ports A&B operate the Tie Cycle and Ports C&D operate the Squeeze and Hooks.

CAUTION

 Check the machine's hydraulic reservoir, after connecting and cycling the unit, for proper fluid level. Operating the machine without the proper oil level can cause damage to both the unit and the machine.

6.4 Crossover Relief Valve

The crossover relief valve located on the Twine Box (comes standard on models made 2023 and later) has been added to protect components in the unit from too much hydraulic pressure coming from machines with more than 2000 lbs of pressure capability.



If there is 3500 lbs pressure coming from the machine, the crossover relief valve will only allow 2000 lbs into the manifold.

6.5 Electrical Connections

The Tie Grabber comes with a splitter handle (shipped inside the Twine Box) that can be attached from the solenoids in the unit's manifold to the machine. Refer to "6.1 One Circuit System (Two Hose Method)" on page 17.

Norden Mfg offers three adapters that replaces the Splitter Handle option to connect to the Skid steers' joystick, (for newer skid steers equipped with electrical plugs).

- 1. 7 pin adapter for Bobcat Skid Steers. PN# 1021130 (Connect the red wire to the white wire of the adapter.)



- 2. 14 Pin adapter for most other skid steers. PN# 1021120

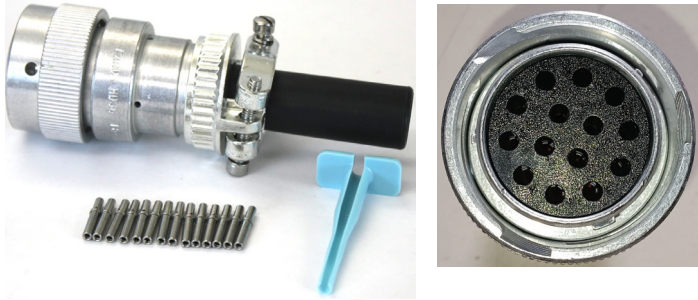

- 3. 8 Pin adapter for some skid steers. PN# 1033520



NOTE: You can also acquire these pin adapters from Skid Steer Genius (skidsteergenius.com) where you will also find helpful YouTube videos.

These adapters allow the user to connect easily to the unit for optimal performance.

7. Threading Twine into the Twine Arm

WARNING

Failure to follow these safety instructions can result in serious injury and possible death.



Read, understand, and follow the Operator's Manual and all safety signs before operating the unit.



Do not allow riders on the unit or the machine.



Stop the machine's engine, remove the ignition key, and wait for all moving parts to

stop before leaving the machine.



Keep all bystanders, especially children, away from the machine and the unit when operating, loading, and unloading.



Keep hands, feet, hair, and clothing away from rotating parts.



Do not place hands, fingers, or arms between moving parts.



Stay away from overhead power lines. Electrocutation can occur without direct contact.

WARNING

Crushing Hazard



Do not stand near the unit when the arm is in motion. Contact with the twine arm

while it is rotating can cause serious injury or can cause the person to become trapped between the twine arm and the unit, which can cause serious injury or death. Keep all bystanders, especially children away from the unit while it is operating.

1. Press and hold the lever/control for the "Twine Arm Forward" circuit to rotate the twine arm, to the position shown, approximately three feet from the knotter.
2. Stop the machine.

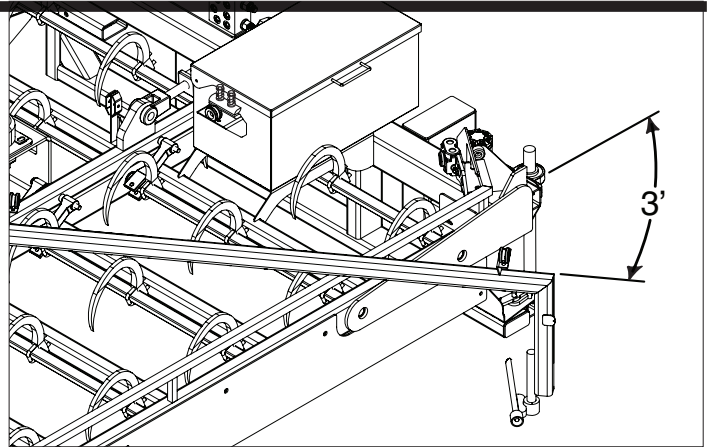

WARNING

Crushing Hazard



Stop the machine on

flat ground before leaving the machine and/or continuing the twine threading operation, always make sure the machine's engine is stopped, the ignition key is removed, all controls are placed in neutral, the parking brake is set, and all hydraulic fluid pressure is relieved (zero pressure). Failure to follow these instruction can result in serious injury.

3. Place the twine spool in the box on top of the unit.

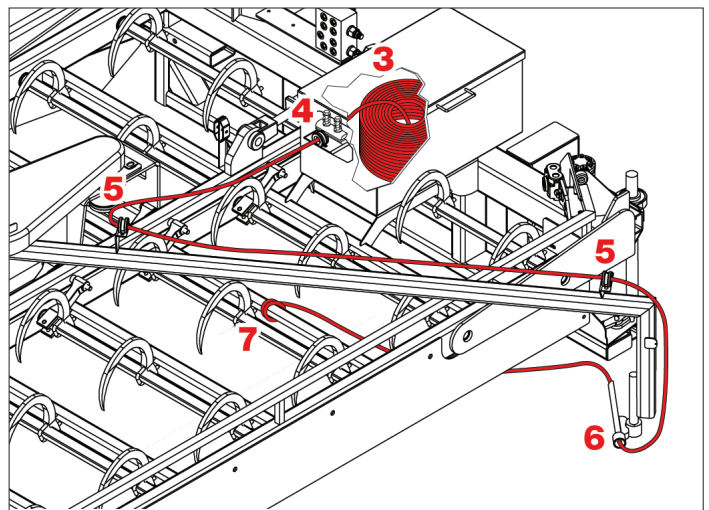

NOTE: A plastic twine with a 170-210 rated knot strength is recommended for this unit. In many cases two rolls of twine can be spliced together by tying a small knot and trimming the ends as close as possible to the knot. This small knot will in most cases thread through the needle.

- To fasten a new spool of twine to the previous, use a reef knot.

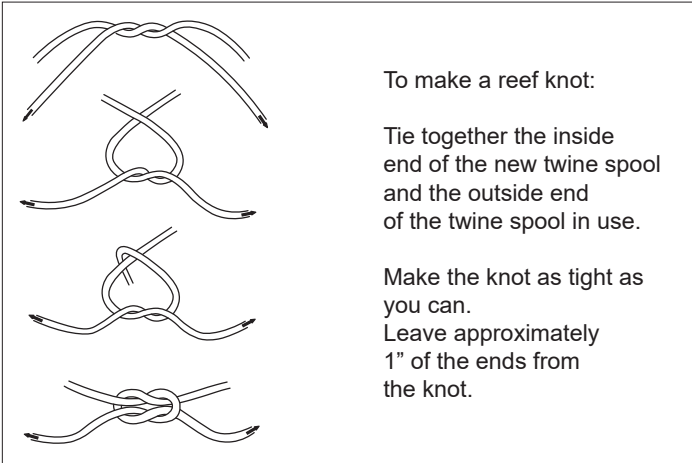

- Thread the twine through the tension bars (4) and through the first twine eyelet.
- Thread the twine through the two eyelets (5) on the twine arm as shown.
- Thread the twine through the needle assembly (6) using the Feeder Rod (shipped inside the Twine Box).
- Tie the end of the twine to one of the frame members (7), as shown.

NOTE: Tying the end of the twine too close to the knotter assembly may cause it to thread the twine incorrectly.

- Make sure everyone is standing clear of the unit particularly the twine arm. Start the machine.

WARNING

Crushing Hazard



Do not stand near the unit when the arm is in motion. Contact with the twine arm

while it is rotating can cause serious injury or can cause the person to become trapped between the twine arm and the unit, which can cause serious injury or death. Keep all bystanders, especially children away from the unit while it is operating.

- Press and hold the lever/control for the "Twine Arm Forward" circuit to extend the needle into the knotter. Continue to hold the lever/control until the knotter indicator comes to a stop.

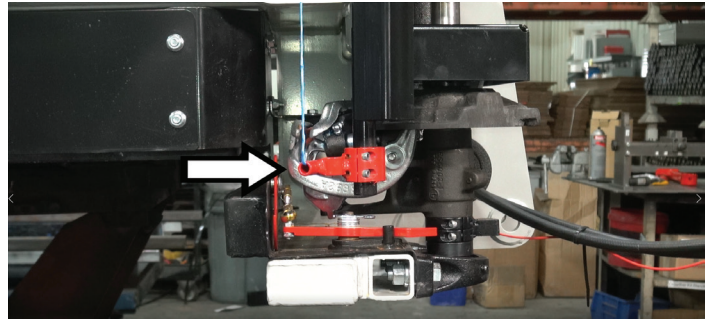

NOTE: The knotter indicator will rotate when the knotter is in motion.



- Press and hold the lever/control for the "Twine Arm Return" circuit to return the twine arm to its retracted position.
- Stop the machine.

WARNING

Crushing Hazard



Stop the machine on

flat ground before leaving the machine and/or continuing the twine threading operation, always make sure the machine's engine is stopped, the ignition key is removed, all controls are placed in neutral, the parking brake is set, and all hydraulic fluid pressure is relieved (zero pressure). Failure to follow these instruction can result in serious injury.



- Remove the short piece of twine that was tied to the frame member in Step 7.
- The unit should now be correctly threaded and ready for operation.

8. Operation

8.1 Operation Safety

WARNING

Failure to follow these safety instructions can result in serious injury and possible death.



Read, understand and follow the Operator's Manual and all safety signs before operation the unit.



Do not allow riders on the unit or the machine.



Stop the Machine's engine, remove the ignition key, and wait for all moving parts to stop before leaving the machine.



Keep all bystanders, especially children, away from the machine and the unit when operating, loading, and unloading.



Keep hands, feet, hair, and clothing away from rotating parts.



Do not place hands, fingers, or arms between moving parts.



Stay away from overhead power lines. Electrocutation can occur without direct contact.

8.2 Pre-Operation

Make sure that the jack-stand is set to the non-weight bearing position when in operation.

Make sure that the fluid in the hydraulic reservoir on the machine is at the proper level to avoid damage to the hydraulic system and ensure proper operation.

Check the twine box for twine to prevent down time in the field and the need to re-thread the twine arm and the needle.

8.3 Tie Grabber Operation

NOTE: In a two circuit system any reference to the button on the splitter handle can be thought of as the second circuit that controls the twine arm and knoter.

1. If necessary, reset the twine arm.

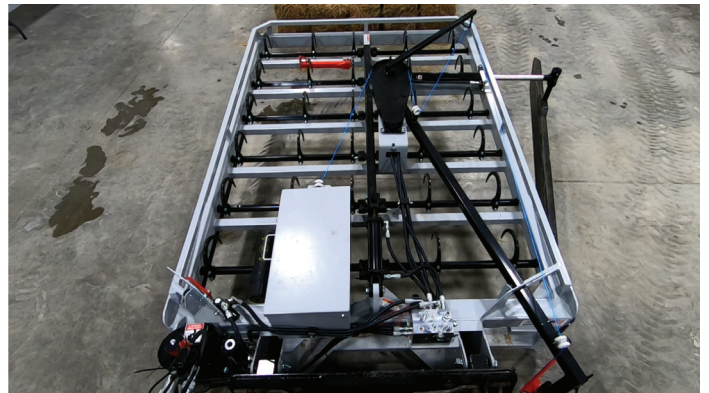

2. Position the unit over the bales. Driving slightly forward and to the right will condense the bales.

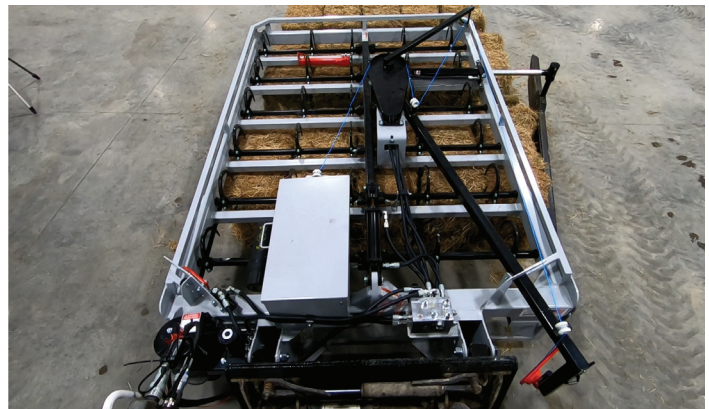

3. Press and hold the lever/control for the "Close Squeeze Arm" circuit. Releasing the lever at any point in the operation will stop the movement.

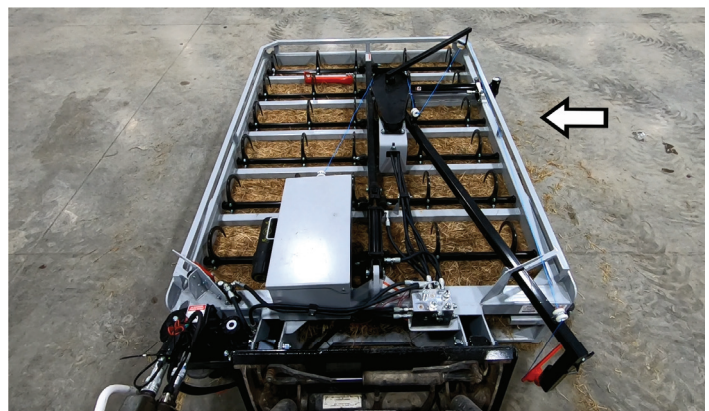

4. Continue to hold the "Close Squeeze Arm" lever/control. Once the squeeze arm is fully closed, the hooks will automatically extend into the bales. Lift the bales.

- Press and hold the button on the splitter handle while operating the lever/control for the hydraulic circuit to extend the twine arm around the bales. Releasing the lever at any point in the operation will stop the movement.

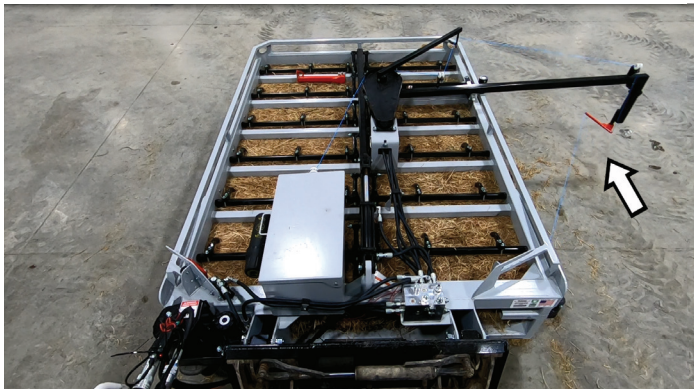

- Continue to hold the button on the splitter handle while operating the lever/control. Once the twine arm needle threads the twine completely, the knotter assembly will automatically tie the twine. Release the button on the splitter handle or lever/control once the knotter is finished operating.

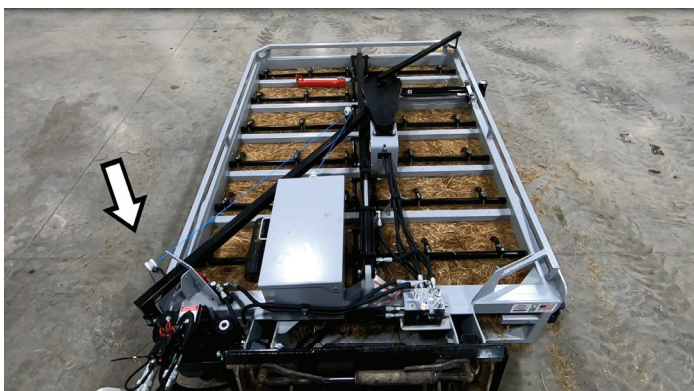

- Set the bales in the desired location. Use the lever/control to release the hooks. As soon as the hooks have released, release the lever/control. This will prevent the squeeze arm from opening.



NOTE: In most cases, fully opening the squeeze arm without lifting the unit off the bales, can cause the twine to break or the bundle of bales to loosen, due to the twine catching on the squeeze arm and stretching.

- Lift the unit up and simultaneously back straight away from the bales. Once clear of the bales, activate the squeeze arm open circuit to open the squeeze arm.



- Press and hold the button on the splitter handle, while operating the lever/control for the hydraulic circuit, until the twine arm returns to its retracted position. Release the button and lever/control. Releasing the lever at any point in the operation will stop the movement.

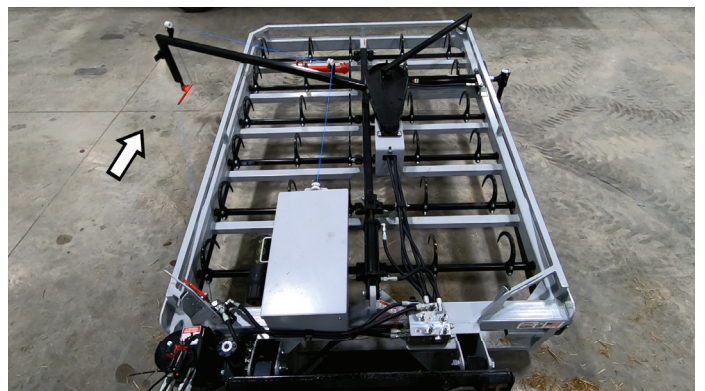

8.4 Normal Knotter Operation

1. The Needle brings the twine into the knotter.

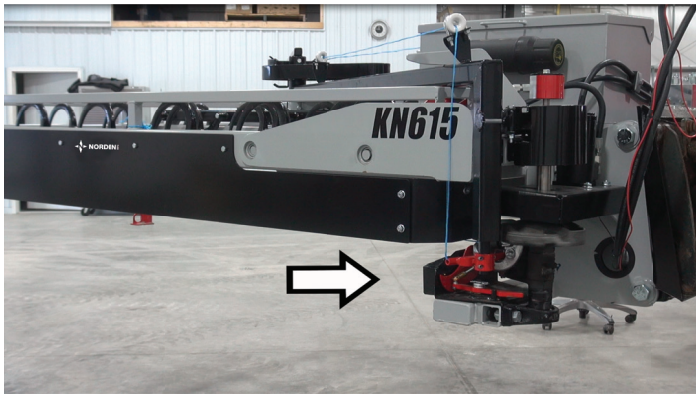

2. At the same time the needle goes into the knotter, the twine arm presses down on the actuation lever (A) which presses on the bolt (B) and opens the plunger valve. This sends hydraulic fluid to the motor which rotates the knotter mechanism.

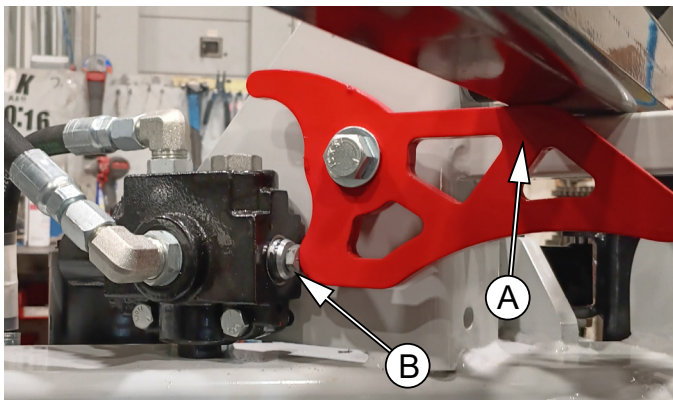

CAUTION

 The hydraulic oil flow through valve is controlled by the bolt. A 1/16 inch gap is recommended between the snap ring and the valve body. Damage will occur to the valve spool if the snap ring contacts the valve body.

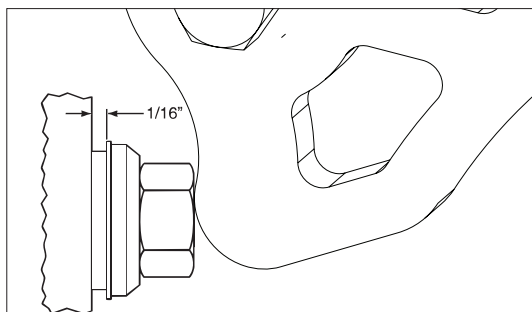

3. The hydraulic motor, through the drive chain, turns the shaft for the assembly. As the cam on the shaft rotates, it contacts the rocker arm which then extends the tucker finger and pushes the twine into the knotter.



4. With the needle extended through the knotter, the knotter then takes the twine and ties the knot.

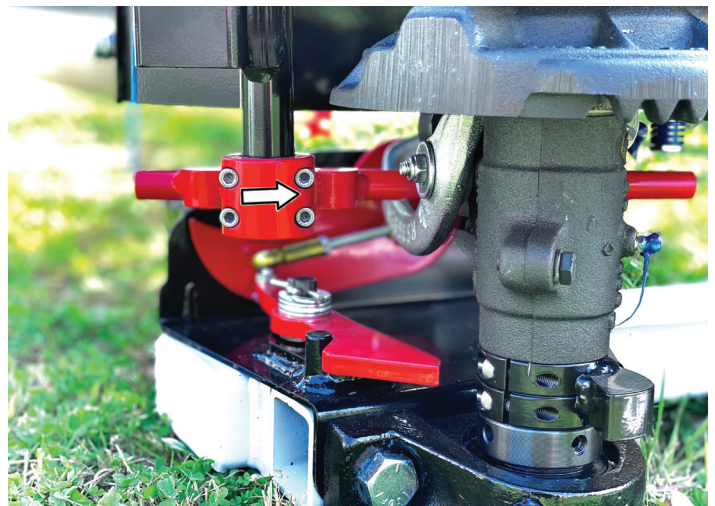

5. As the knotter assembly finishes tying the knot, the shaft has rotated and contacts knotter stop plate. This plate prevents the knotter from further rotation.

When the twine arm returns to its retracted position, the actuation lever releases the plunger valve and stops hydraulic oil flow to the motor. The motor stop plate, part of the twine arm, is also retracted. Since there is no hydraulic flow to the motor it is positioned for the next cycle.

9. Manifold Port Locations and Identification

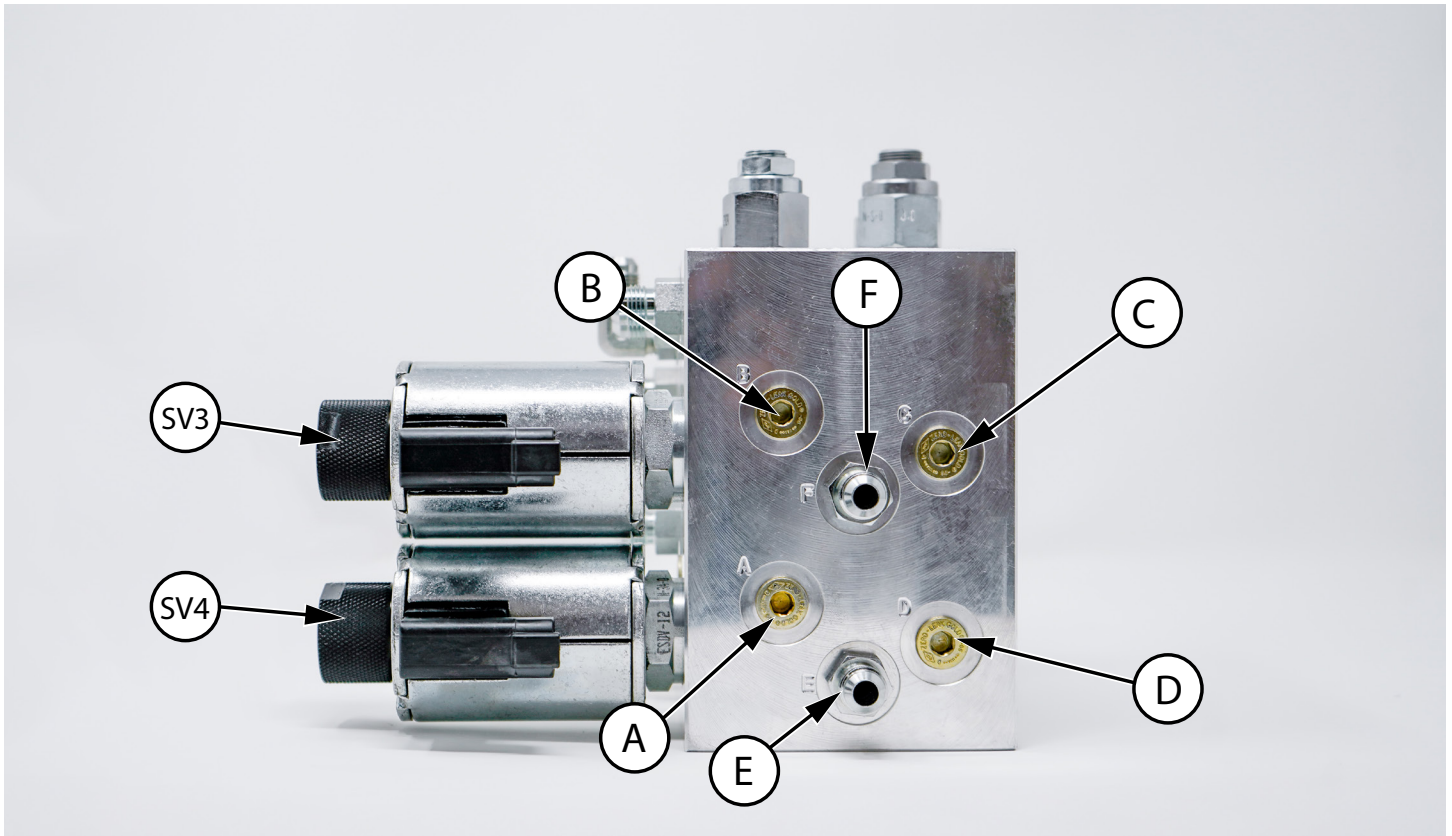

Port ID	One Circuit System Description	Fitting Part Number
A	PLUG	1016480
B	PLUG	1016480
C	PLUG	1016480
D	PLUG	1016480
E	Used as feed line for one circuit system	1009680
F	Used as feed line for one circuit system	1009680

Port ID	One Circuit System Description	Fitting Part Number
A	Used as feed-line for twine-arm/knotter in two circuit system	1009680
B	Used as feed-line for twine-arm/knotter in two circuit system	1009680
C	Used as feed-line for hook/squeeze in two circuit system	1009680
D	Used as feed-line for hook/squeeze in two circuit system	1009680
E	Plug	1016480
F	Plug	1016480

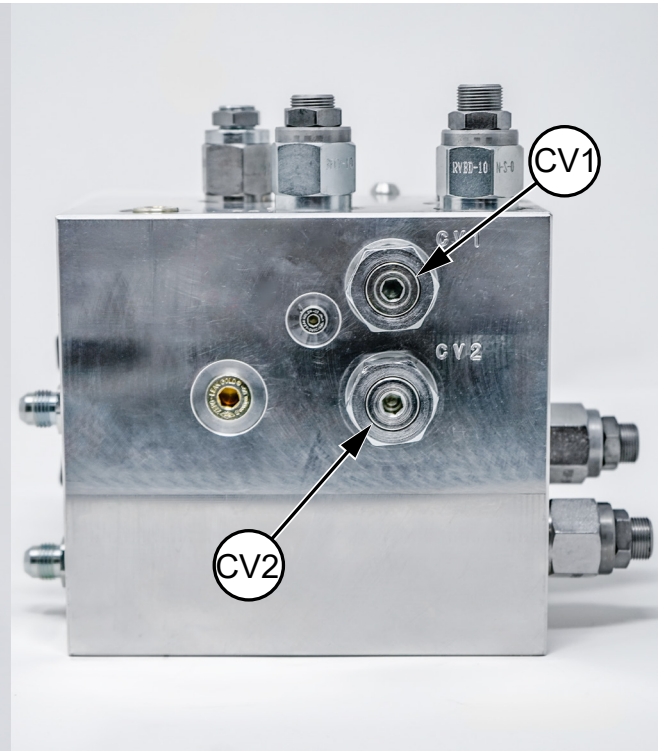
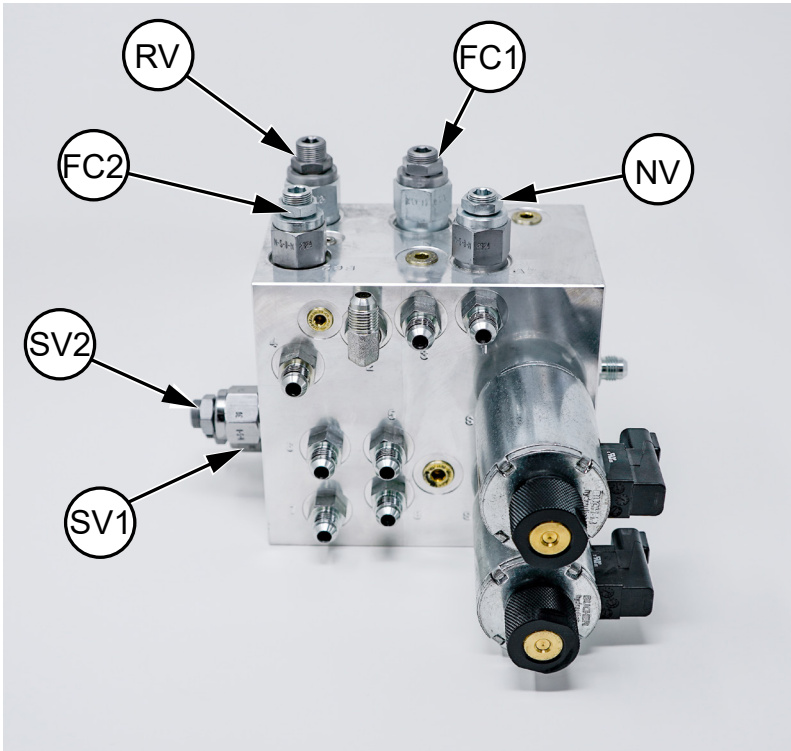

Port ID	One and Two Circuit System Description	Fitting Part Number
NV	Adjusts the knotter speed	1009630
FC1	Adjusts twine arm speed coming into the knotter	1009650
FC2	Adjusts twine arm speed leaving the knotter	1009640
RV	Crossover relief valve	1009660
SV1	Adjusts when squeeze moves after hook release	1009010
SV2	Adjusts when hooks start to grab bales, after the squeeze arm is in	1009010
CV1	Check valve, non-adjustable	1009670
CV2	Check valve, non-adjustable	1009670

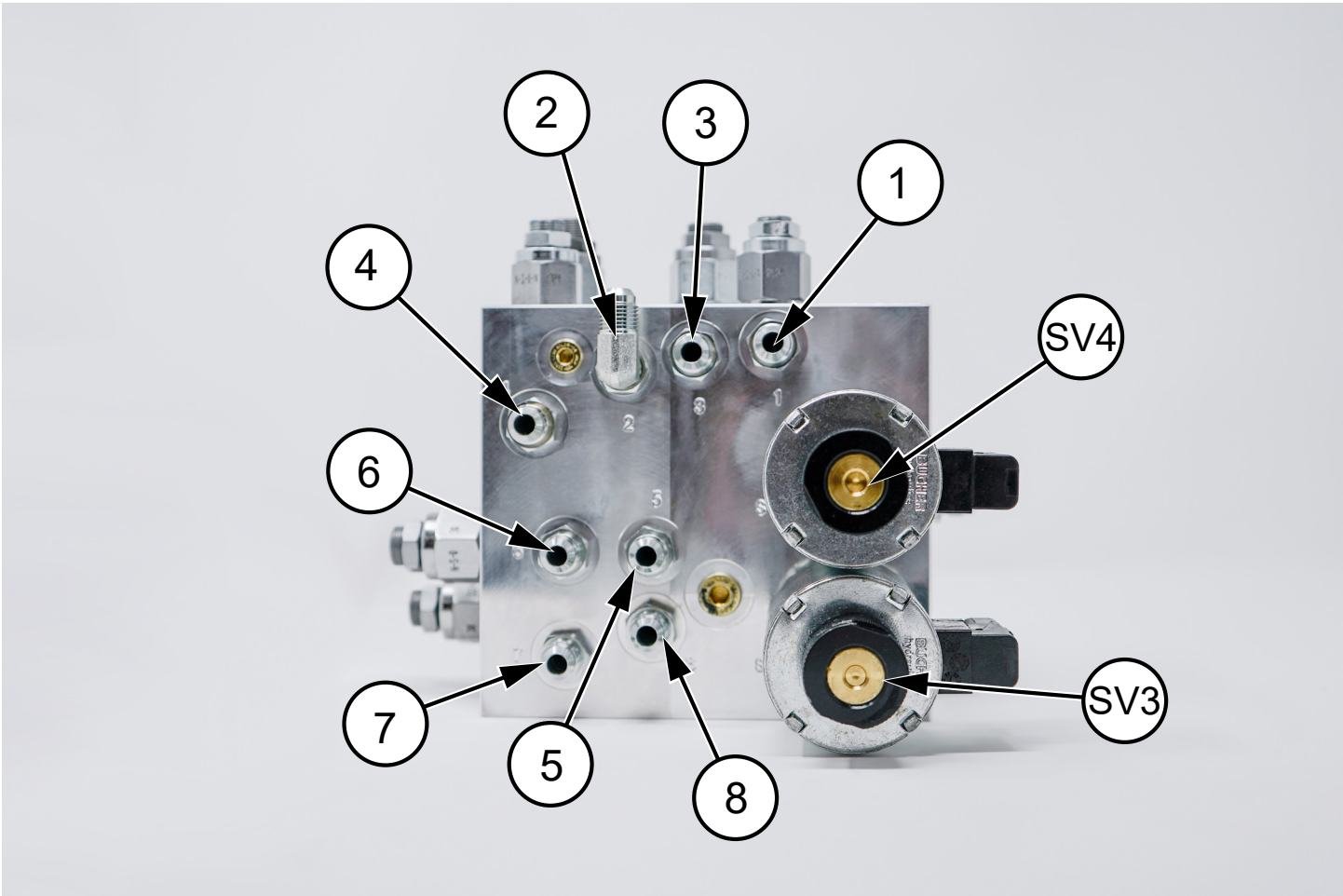

Port ID	One Circuit System Description	Fitting Part Number
SV3	Splitter solenoid	1034280
SV4	Splitter solenoid	1034280
1	To plunger valve	1009680
2	To knotter motor right	1009690
3	To twine arm motor right	1009680
4	To twine arm motor left	1009680
5	To squeeze retract	1009680
6	To hooks extend	1009680
7	To squeeze extend	1009680
8	To hooks retract	1009680

Port ID	One Circuit System Description	Fitting Part Number
SV3	Cavity plug	1017550
SV4	Cavity plug	1017550
1	To plunger valve	1009680
2	To knotter motor right	1009690
3	To twine arm motor right	1009680
4	To twine arm motor left	1009680
5	To squeeze retract	1009680
6	To hooks extend	1009680
7	To squeeze extend	1009680
8	To hooks retract	1009680

10. Setting and Timing

NOTE: All of the cartridges come factory set and tested. Should an adjustment be needed, loosen the set nut on the valve, using a 5/16" Allen Key, turn the valve no more than 1/4" at a time. Retesting the operation between each adjustment. Once set, be sure to tighten the jam nut. The sequence valves are used to cycle the unit between various functions. When the hydraulic oil pressure reaches the desired setting for the initial function, the oil flow is diverted to the second function. For example, when the squeeze arm clamps onto the blades, the pressure builds and then the sequence valve directs the flow to the bale hooks which are then pushed into the bales.

SV1

The SV1 port on the manifold has one of the sequence valve cartridges in it. It is used to adjust when the squeeze bar starts to open.

SV2

The SV2 port on the manifold has one of the sequence valve cartridges in it. It is used to adjust when the hooks start to grab the bales.

FC1

The FC1 port on the manifold has the back flow control valve in it. It is used to adjust the twine arm speed as it goes into the knotter.

FC2

The FC2 port on the manifold has one of the flow control valves in it. It is used to adjust the twine arm speed as it leaves the knotter.

NV

The NV port on the manifold has one of the flow control valves in it. It is used to adjust the knotter speed.

RV

The RV port on the manifold has the crossover relief valve in it. Adjusting the crossover relief will adjust how much hydraulic pressure goes to the knotter.

10.1 Accessing the Knotter Components

WARNING



When completing a maintenance or service function, make sure all safety shields and devices are installed before placing the unit back in service.



Keep hands and fingers away from rotating and/or mating parts to prevent injury.



Keep hands and fingers away from the knife arm and knife blade. When changing the knife blade, wear hand protection and use CAUTION.

SAFETY INSTRUCTIONS



When accessing and making adjustments to the knotter, use the correct tools for the parts being adjusted.

Start by removing the knotter indicator, the knotter stop shield, the knotter chain shield, the knotter motor chain, and the knotter service bolt.

This will allow the knotter assembly to swing out of the knotter pocket and into a servicing position for the knotter and its components.

10.2 Knife Arm

The knife arm should be adjusted to allow bill hook finger (1) to rotate freely, but not contact knife arm (3).

The twine guide area (2) must be kept smooth to prevent twine breakage. Once a groove begins to wear into the twine guide area, knife arm (3) must be replaced.

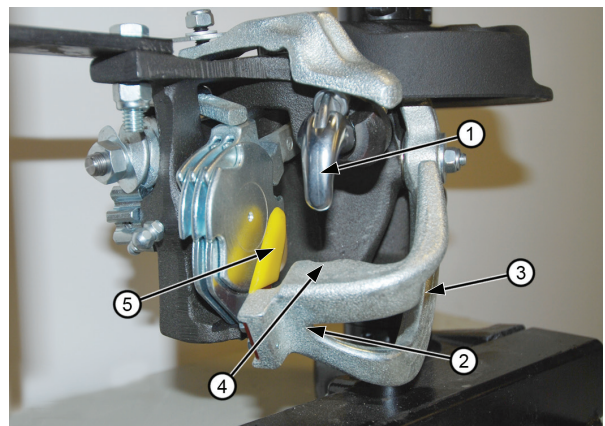

Replace knife (PN#1017260) (5) as soon as the knot begins to have excess twine on the end or the twine is frayed.

10.2.1 Adjusting the knife arm (3).

The wiping face of the knife arm must slide smoothly over the bill hook with a slight contact to strip the knot off of the bill hook.

NOTE: There should not be a gap between the bill hook and the wiping face of the knife arm.

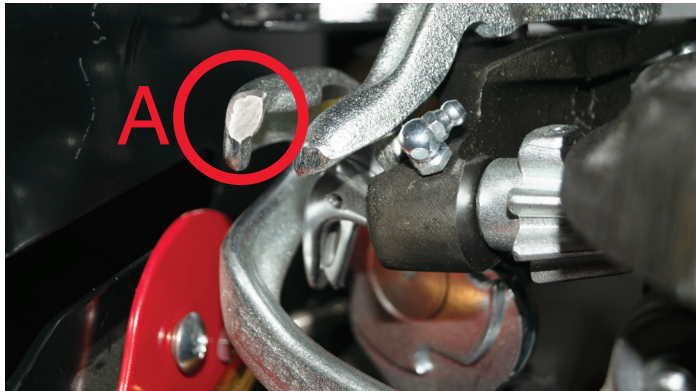

A. The Knotter Knife Arm is trimmed by the manufacturer to prevent the twine from getting tangled.

If over time, there becomes a gap, use a mallet and tap the arm inward until it rubs against the bill hook.



10.3 Testing and Adjusting Knotter Assembly



Pinch Point



Keep hands and fingers away from rotating and/or mating parts to prevent injury.

To test or adjust the knotter, remove the knotter drive chain and turn the knotter by hand. This shows each part working and allows any necessary adjustments.

1. These two illustrations show the twine coming into the knotter, the standing end (1a) of the twine being held by the knotter, and the working end (1b) of the twine going around the bales and being held back into the knotter by the needle.

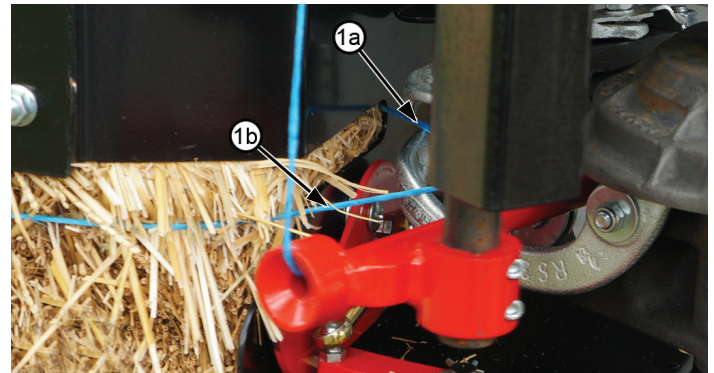

2. When the tucker finger (2) is in the down position, as shown, the bill hook (3) should also be pointed down.
3. As the knotter cycles, the cam (3) rotates and contacts the rocker arm (4) causing the tucker finger (2) to push the twine into the knotter.
4. If the tucker finger (2) does not push the twine far enough into the knotter, the bill hook finger (5) will not properly catch the twine (1) and the knot may or may not tie correctly.

NOTE: The needle is not shown in these some of illustrations to clearly show the position of the twine in the knotter.

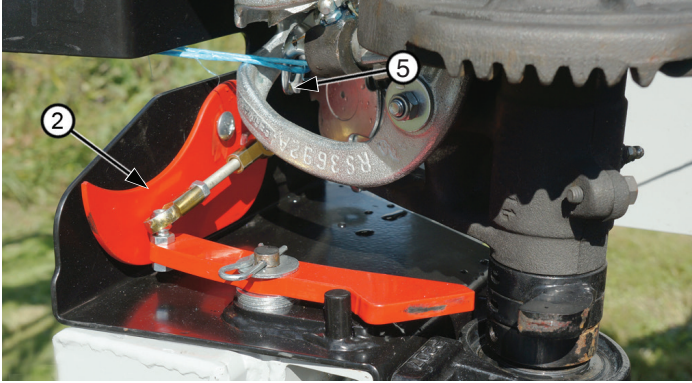

5. The tucker finger (2) holds twine (1) as the bill hook (5) rotates upward. If the bill hook does not catch both strands of twine, the tucker finger may need to be adjusted inward.

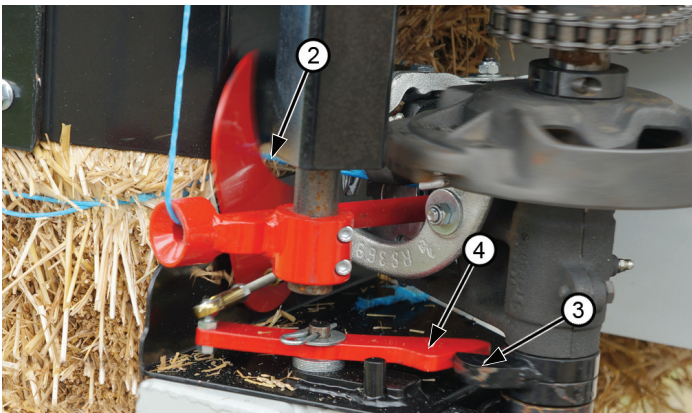

6. The bill hook continues to rotate. The bill hook has made a half revolution. At this point, the rocker arm cam is about to release the rocker arm and allow the tucker finger to return to its resting position. If the tucker finger spring (6) is broken, stretched, or missing the knotter will not function properly.

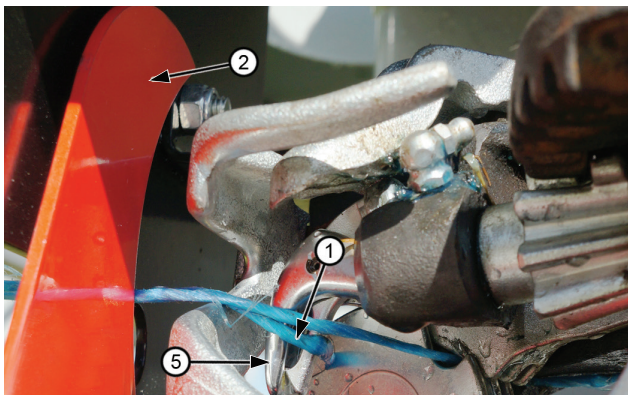

7. The bill hook has a complete revolution. As the tucker finger spring (6) pulls the tucker finger downward, the knife arm slides the knot off the bill hook and the knot is tied.

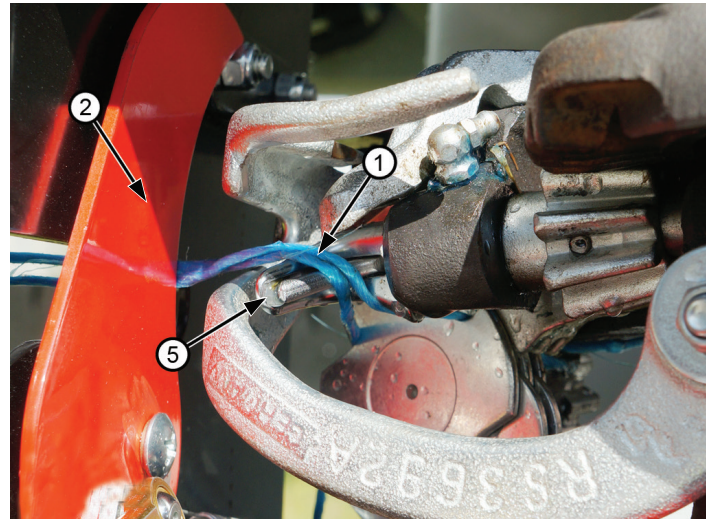

NOTICE

If the timing of these moving parts is incorrect, the tucker finger and the needle can come into contact with each other resulting in damage.

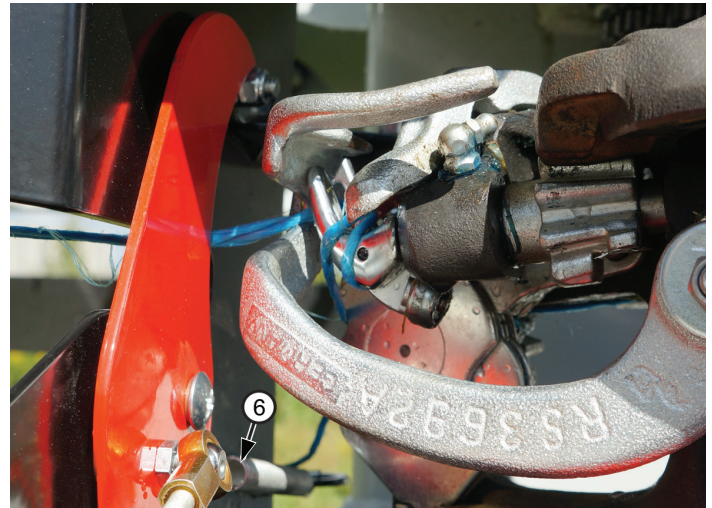

NOTE: To make these adjustments, the knotter needs to be in the reset position.

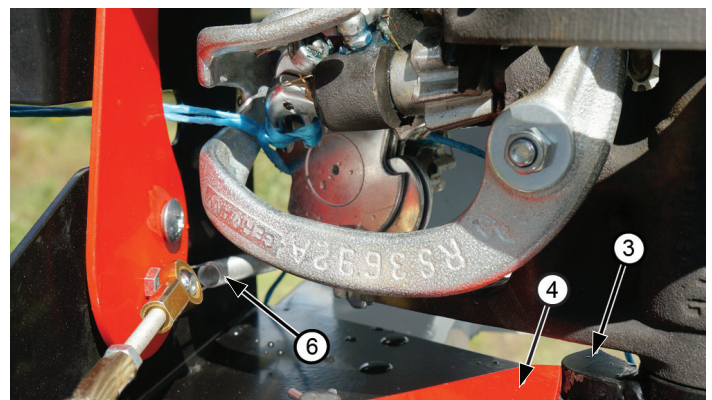

10.4 Twine Disc Assembly

The twine disc assembly holds the standing end of the twine in place until the needle brings the working end of the twine into the knotter. Should the twine disc come out of adjustment (not in the position shown when the knotter is in resting position) you can make adjustments as shown below.

1. Loosen the nut until there is a 1/32 inch gap between the nut and the worm gear.
2. Lightly tap the threaded shaft to loosen the worm gear.
3. Rotate the twine disc assembly until the twine disc hook is in the original position. Refer to the first photo of the twine disc assembly.
4. Tighten nut to 18.5 ft. lbs. (25 N m).
5. Cycle the knotter and re-check the position of the discs.

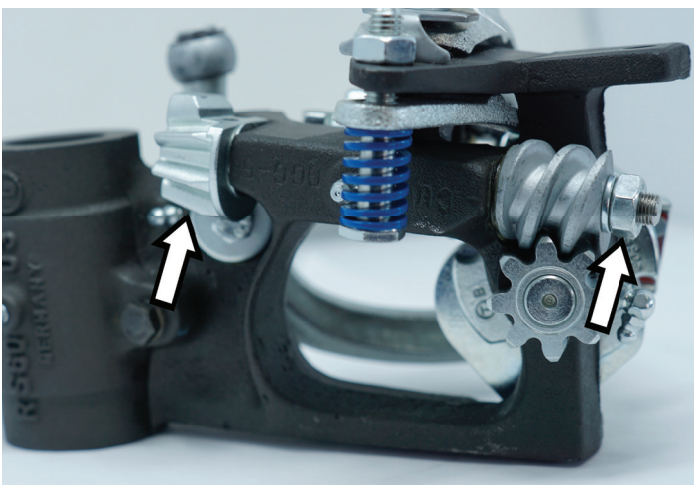
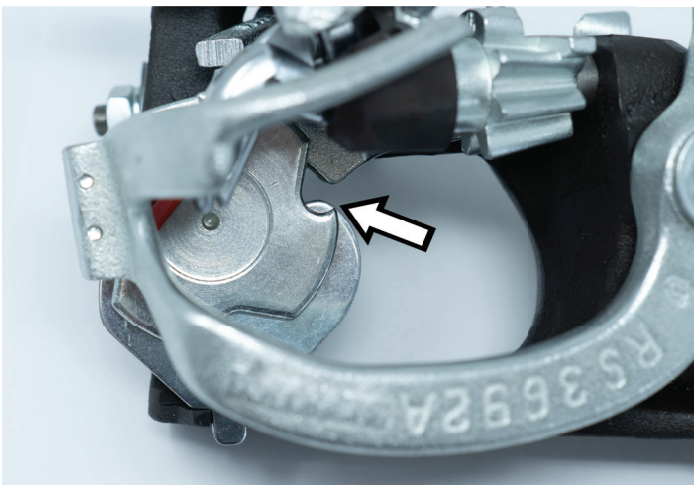

10.5 Needle Position Within the Knotter

When properly set, the outside of the needle should be 1/8 inch from the face of the twine holder.

To set the needle loosen the 4 bolts in the needle collar until the needle can move freely. Position the needle in the proper place. Tighten the 4 collar bolts in an X pattern in order to keep the needle in line. When tight recheck the alignment of the needle.

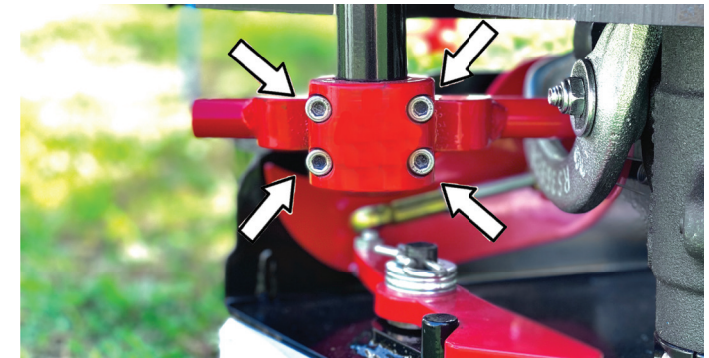
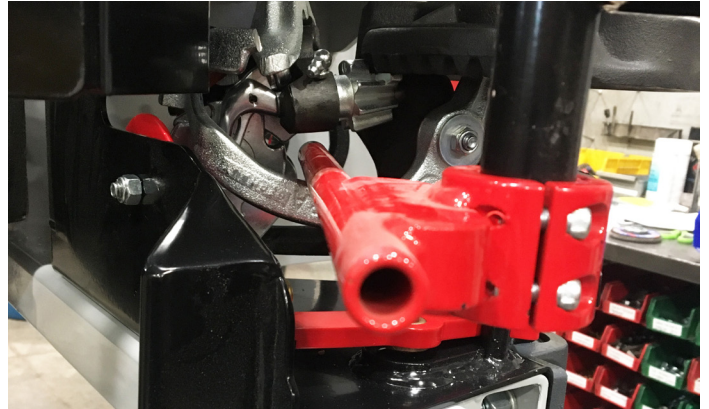

10.6 Cam Timing Mark

The rocker arm cam can move out of alignment over time through use. Should this happen, loosen the bolts in the cam collar.

Move the collar around the shaft until the timing mark on the cam's collar lines up with the mark in the knotter frame casting. Once the cam is adjusted correctly, re tighten bolts in the collar.

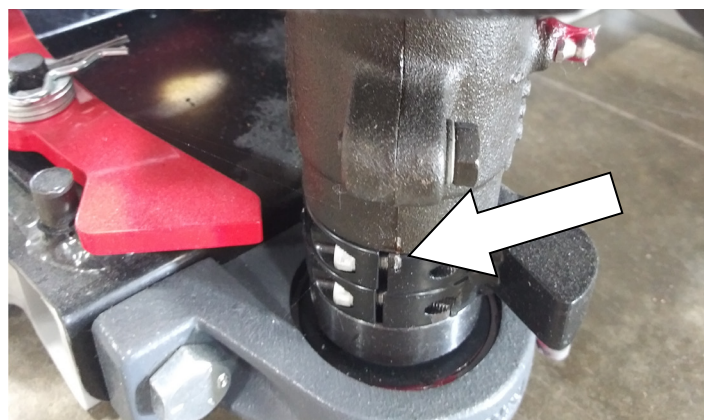

10.7 Tucker Finger

The purpose of the tucker finger is to push the twine to the back of the twine slot in the knotter pocket. If the tucker finger does not extend far enough, shorten the linkage (turn clockwise).

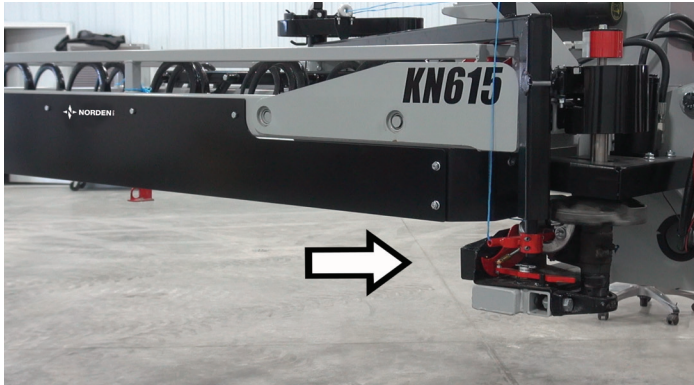

Remove the hairpin clip and washers. Remove the rocker arm from the pivot shaft. Rotate the rocker arm clockwise to shorten the shaft or counterclockwise to lengthen the shaft.



NOTE: Only rotate the rocker arm one revolution at a time.

Reinstall the rocker arm on to the shaft. Reinstall the washer and the hair pin clip. Cycle the knotter and make more adjustments as necessary.

10.8 Knotter Drive Chain

Periodically check the chain that operates the knotter. There should be approximately 1/8" to 1/4" of play in the chain.

To adjust the tension on the chain, loosen four bolts and adjust the tension bolt to achieve the proper chain tension.

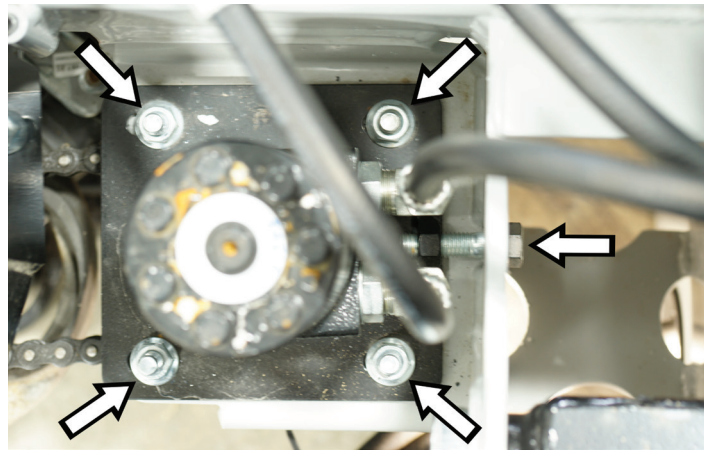

10.9 Twine Arm Drive Chain

Periodically check the chain that operates the twine arm. There should be approximately 1/8" to 1/4" of play in the chain.

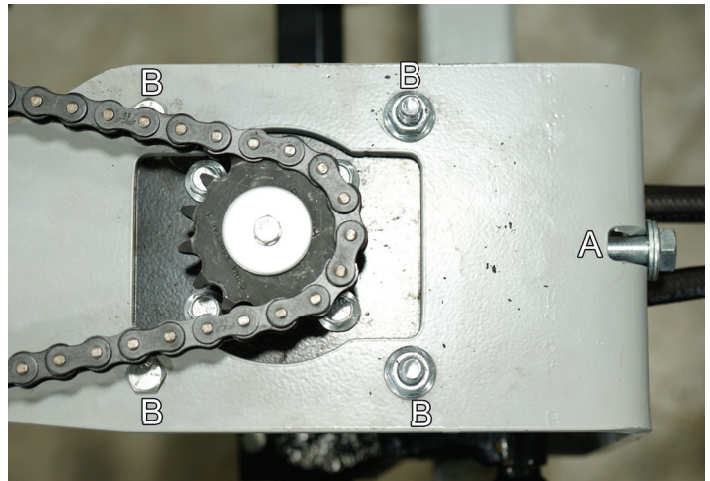

Before checking the chain, remove the chain shield. To adjust the tension on the chain, loosen the four bolts (B) and adjust the tension bolt (A) to achieve the proper chain tension.

10.10 Twine Tensioner

The twine tension can be increased or decreased using bolts to vary the spring pressure on the spring plate. The springs should be compressed to approximately 1 1/4".

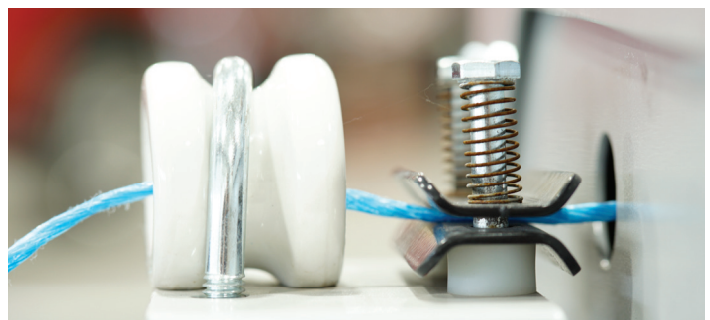

11. Maintenance

11.1 Maintenance Safety

DANGER

Failure to comply with the following safety instructions can and will result in serious injury and possibly even death.

Crush Hazard

 **NEVER WORK UNDERNEATH the unit.** Always set the unit on safety stands or on the ground with the jack stand in the weight bearing position.

High-Pressure Fluid Hazard

 **DO NOT use your bare hand to check for potential leaks.** Always use a board or cardboard when checking for a leak.

Escaping hydraulic fluid under pressure, even a pinhole size leak, can penetrate body tissue, causing serious injury and possible death. If fluid is injected into your skin it must be treated immediately by a doctor familiar with this type of injury.

Keep all hydraulic lines, fittings, and couplers tightly secured and free of leaks.

WARNING

Damaged Parts Hazard

 **Do not use the unit if any parts are damaged.** If the unit is believed to have a defect which could cause it to work improperly, immediately stop using it and remedy the problem before continuing.

Personal Protective Equipment

 **Wear close fitting and belted clothing to avoid getting caught in moving parts.** Wear personal protective equipment (PPE), which may include hard hat, safety glasses, safety shoes, gloves, etc. Appropriate for the work site and working conditions.

Disconnect Hydraulics

 **To prevent injury due to possible unexpected movement, disconnect the hydraulics from the machine before performing any maintenance procedure.**

No Unauthorized Modifications

 **Do not modify the unit or safety devices.** Unauthorized modifications may impair the unit's function, or create safety hazards, and will void the unit's warranty.

Only perform welding repairs to the unit and it's components, after contacting Norden Mfg LLC for guidance and approval.

If the unit has been altered in any way fro the original design, the manufacturer does not accept any liability for injury or warranty.

Repair welding must be one with care and with procedures that may be beyond the capabilities of the ordinary welder.

Any approved welding repair should be performed by a welder who is certified in accordance with the American Welding Society (AWS) Standards and all guidance given by Norden Mfg LLC should be followed.

Good Working Condition

 **Keep all parts in good condition and properly installed.** Fix damage immediately. Replace worn or broken parts.

Replacement Parts

 **If replacement parts are necessary, genuine factory replacement parts must be used to restore the unit to its original specifications.** The manufacturer will not accept responsibility for damage as a result of the use of unapproved parts.

Safety Shields and Devices

 **When completing a maintenance or service function, make sure all safety shields and devices are installed before placing the unit back in service.**

Trapped Air Hazard

 **When installing, replacing, or repairing hydraulic system cylinders or parts, make sure that the entire system is charged and free of air before resuming operations.** Failure to bleed the system of all air can result in improper machine operation, causing severe injury.

Zero Pressure



Relieve pressure from the hydraulic system before servicing or disconnecting from the machine.

Personal Injury Hazard



Repairs or modifications to the unit can result in serious injury or death, should these repairs fail.

High-Pressure Hazard



Do not make any temporary repairs to the hydraulic lines, fittings, or hoses using tape, clamps, or cement. The hydraulic system operates under extremely high Pressure and temporary repairs may fail suddenly and create a hazardous and/or dangerous situation.

SAFETY INSTRUCTIONS

The following safety instructions are provided to help prevent injury or limit equipment damage.

Safety Equipment



A fire extinguisher and first aid kit should be readily accessible while performing maintenance on this unit.

Clean Work Area



Do not leave tools lying around the work area. Follow good shop practices. Keep service area clean and dry. Be sure electrical outlets and tools are properly grounded. Use adequate light.

Use the Correct Tools



Use the correct tools, jacks, hoists, or other tools that have capacity for the job.

NOTE: After working on the hydraulic system, cycle the unit two or three times to bleed the system and let any air out of the lines.

11.2 Pre-Maintenance

WARNING

Failure to comply with the following safety instructions can result in serious injury or death.

Preventive maintenance is one of the most cost effective practices that any equipment owner can implement. Taking a few minutes of your time to inspect the unit can save hundreds or even

thousands of dollars. These savings can come from:

1. Increased operating time (no unscheduled breakdowns in the field).
2. Normal wear items will last longer because they have been properly maintained and lubricated.
3. Less chance of someone becoming injured due to parts that fail because of mistreatment or abuse.

Preventive maintenance should only be completed by qualified persons. In no way are these instructions intended to encourage service of the unit by anyone who is not qualified to do so. The overall performance of the unit is directly related to the skill and knowledge of the person performing the service. If the mechanic cannot see potential problems, or is unaware of the signs of potential problems, the service may be a costly waste of time.

Before working on the unit, fully disconnect the unit from the machine. After servicing, be sure all tools, parts, and service equipment are removed. Where replacement parts are necessary for periodic maintenance and servicing, genuine factory replacement parts must be used to restore the equipment to original specifications. The manufacturer will not accept responsibility for damage or injury as a result of the use of non-OEM parts or accessories.

If the unit has been altered in any way from the manufacturer's original design, the manufacturer does not accept any liability for injury, warranty, or machine damage.

11.3 Lubricating

Use an SAE multipurpose high temperature lithium grease with extreme pressure (EP) performance or an SAE multipurpose lithium based grease.

Wipe grease fittings with a clean cloth before greasing to avoid injecting dirt and grit into the joint.

Apply grease until new grease can be seen coming out of the joint.

Do not let excess grease collect on or around parts, particularly when operating in sandy areas.

Replace and repair broken grease fittings immediately

If any grease fitting will not take grease, remove and clean it thoroughly. Also clean the lubricant passageway. Replace the fitting if necessary.

11.3.1 Twine Arm

Grease the fitting found on the twine arm collar. This is very important to keep greased.

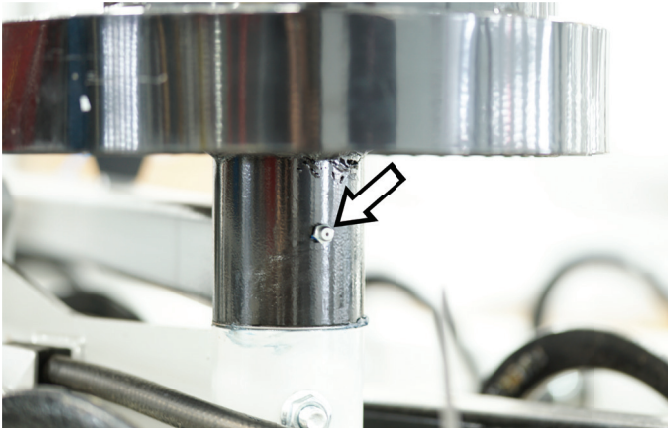

11.3.2 Squeeze Arm

Grease the three fittings found in the following places: squeeze arm frame mount, squeeze arm cylinder pivot point, and squeeze cylinder mount pivot point.



NOTE: It's important to wipe all excess grease from fitting to avoid collecting debris and twine tails

11.3.3 Knotter Assembly

Grease all 7 fittings on the Knotter Assembly

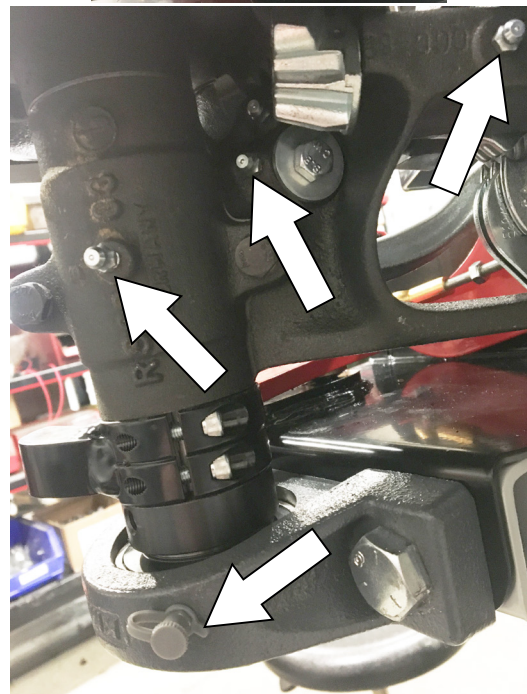
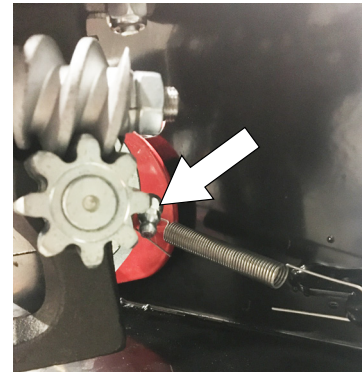
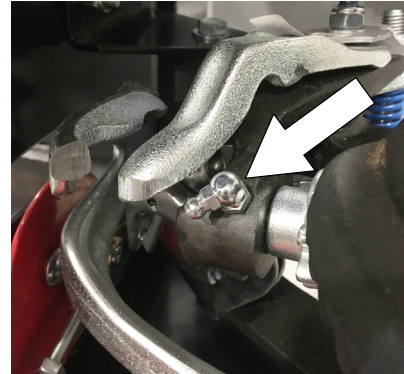
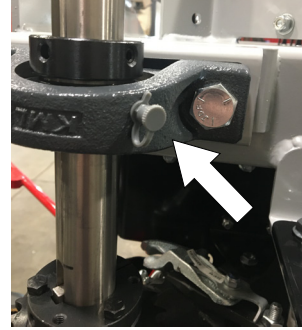

11.3.4 Chain Lubrication

Lubricate the chains with a light chain oil.

Cycle the chains, reapply oil as needed. Replace the chain shields when complete.

NOTE: The chains should be checked for wear and replaced if needed. Check the tension on the chain after lubricating.

11.3.5 Flow Control Valve Plunger

The plunger on the flow control valve (shown in the following picture) must be lubricated in accordance with the maintenance service schedule. Lubricate the plunger shaft (shown in illustration) with a light oil.

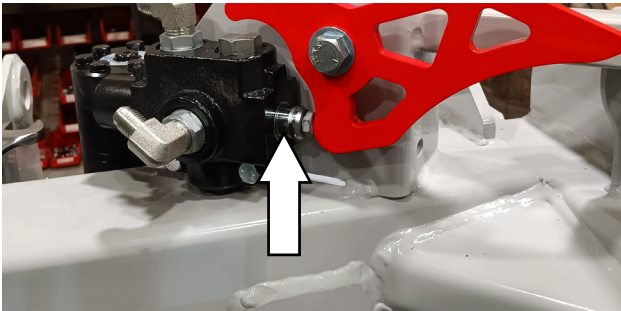

11.4 Hydraulic Hoses

When replacing hydraulic hoses refer to Safety instructions in “5.2 Hydraulic Safety” on page 16.

Hydraulic hoses should be replaced when:

- The hoses are cracked.
- The hoses are frayed.
- A hose has a leak of any size.
- A hose has been smashed, slashed, crushed, crimped, or damaged in anyway.

If there are hoses that are in need of replacement, using gloves and the proper wrench, remove one hose at a time making note as to where it was connected to the manifold. Most of the hoses have a Female JIC Flair Swivel End (6G-6FJX) and can be made locally, ordered from a dealer, or from Norden Mfg. LLC. Once a replacement hose has been obtained it can be reconnected to the port noted before.

Make sure when tightening the hydraulic hoses not to cross thread the fittings (if cross threading occurs it will damage the threads and cause leaks).

Make sure components in the hydraulic system are kept clean and in good working condition.

The most common reason for hydraulic component failure is contamination of the oil. Keep all hydraulic access areas completely clean, such as around the hydraulic oil filler cap, filter, and connection points. Replace any fittings, hoses, or other components where leakage is observed. Clean up any spilled hydraulic oil.

11.5 Springs

The unit has four main springs.

The first two are the twine tensioner springs, refer to “10.10 Twine Tensioner” on page 32.

The third is the Knotter Stop Spring. It is located on the end of the twine arm, and puts tension on the knotter stop. It should be installed with the opening of the spring hooks facing away from the knotter.

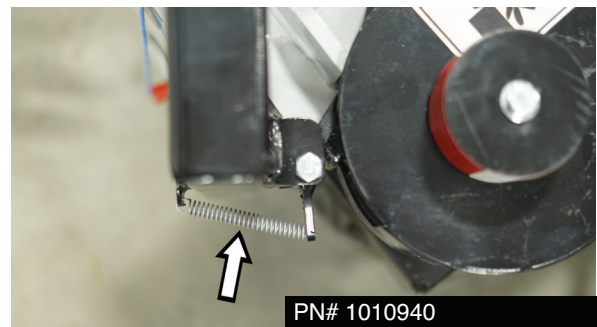

The fourth is the Tucker Finger Spring. It is located in the knotter pocket, hooked between the knotter pocket eyelet and the tucker finger linkage.

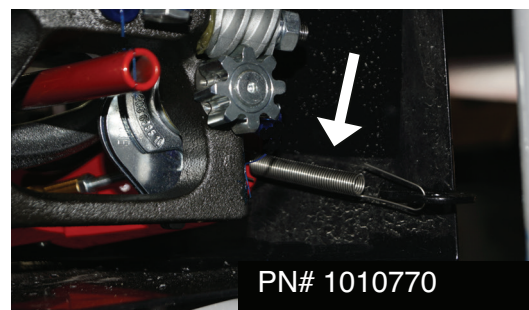

12. Maintenance Service Schedule Sheet

Serviced by																																			
Every 70-100 Cycles																																			
Grease the twine arm. Refer to "11.3.1 Twine Arm" on page 35																																			
Grease the squeeze arm pivot shafts. Refer to "11.3.2 Squeeze Arm" on page 35																																			
Grease the 7 Knotter fittings. Refer to "11.3.3 Knotter Assembly" on page 35																																			
Remove any chaff and twine cutoffs from the knotter pocket.																																			
Every 700-1000 Cycles																																			
Clean the knotter of old grease dirt and twine debris. Refer to "11.3 Lubricating" on page 34																																			
Grease the Knotter. Refer to "11.3.3 Knotter Assembly" on page 35																																			
Grease the chains. Refer to "11.3.4 Chain Lubrication" on page 36																																			
At the Start of the Season																																			
Check that the Shaft Collar holding the Hub Cam in place is Properly Installed and Tightened.																																			
Make sure all bolts, pins, and nuts are properly installed and tightened on the bracket.																																			
Check that the red actuator arm is in the down position.																																			
Check that the stop spring and the tucker finer spring are properly installed and in working order. Refer to "11.5 Springs" on page 36																																			
Inspect the unit for wear and damage.																																			
Clean the knotter and knotter pocket.																																			
Grease all points. Refer to "11.3 Lubricating" on page 34																																			
Follow the twine threading process "7. Threading Twine into the Twine Arm" on page 20																																			
Run the knotter three times and check the knots.																																			
At the End of the Season																																			
Clean out the unit.																																			
Lubricate the chains.																																			
Grease all points. Refer to "11.3 Lubricating" on page 34																																			
Lubricate the plunger on the flow control valve																																			
Remove the twine from the twine arm and the knotter.																																			
Follow the storage process "13. Storage" on page 39																																			

12.1 Torque Requirements



Equipment Failure



The proper torque value for bolts and cap screws is identified by their head markings. Replacing a high grade bolt with a lower grade bolt will lead to equipment failure and could result in injury or death. Always use replacement bolts with the same grade markings as the removed bolt.

It is extremely important to apply and maintain proper torque on all bolts and valves. Use a torque wrench to assure the proper amount of torque is being applied to the fasteners.

Start all bolts, nuts and valves by hand to prevent cross threading.

Torque figures indicated in the following charts are used for non-greased or non-oiled threads unless otherwise specified. Therefore, do not grease or oil bolts or cap screws unless otherwise specified in this manual when using locking elements, increase torque values by 5%.

The following charts give correct torque values for various bolts, cap screws, and valves. Tighten all bolts to the torque specified in the charts, unless otherwise noted. Check the tightness of the bolts periodically, using the bolt torque chart as a guide. Always replace hardware with the same grade bolt.

NOTE: The u-bolt used on the twine insulators is not tightened using the torque guide. Instead they are tightened loosely so that the insulators do not crack or shatter.

12.1.1 Bolt Torque Requirements Chart

Bolt Diameter	English Bolt Torque Specifications					
	Grade 5		Grade 8		ASTM A574	
	3 Radial Lines Grade 5		6 Radial Lines Grade 8		Socket Head Cap Screw	
	ft.lbs.	N·m	ft.lbs.	N·m	ft.lbs.	N·m
1/4"	9	12	12	17	14	18
5/16"	19	25	27	36	29	38
3/8"	33	45	45	63	51	69
7/16"	53	72	75	100	81	109
1/2"	80	110	115	155	124	168
9/16"	115	155	165	220		
5/8"	158	215	220	305	238	322
3/4"	290	390	398	540	423	573
7/8"	420	570	650	880	682	924
1"	630	850	970	1320	1022	1385

12.1.2 Valve Torque Requirements

Valve Part Number	Valve Description	Port ID	Ft. Lbs.	N-m
1009630	Needle Flow Control Valve	NV	30	41
1009650	Back flow control Valve	FC1	40	54
1009640	Free Flow Check Control Valve	FC2	30	41
1009660	Crossover Relief Valve	RV	32	43
1009010	Sequence Valve	SV1	40	54
1009010	Sequence Valve	SV2	40	54
1009670	Check Valve	CV1	40	54
1009670	Check Valve	CV2	40	54
1034280	Solenoid	SV3	50	68
1034280	Solenoid	SV4	50	68

13. Storage

WARNING

Failure to follow these safety instructions can result in serious injury and possible death.



Do not permit anyone, especially children to play on or around the stored unit.



Do not store the unit where it will be exposed to livestock. Exposure to livestock could result in damage to the unit and livestock injury or death.

SAFETY INSTRUCTIONS

Read, understand and follow this manual, all safety signs, and all other equipment manuals, before moving the unit.

13.1 Placing in Storage

When preparing to store the unit select an area that is dry, level, free of debris, and away from human activity (ideally inside a building) for off season storage.

Use the following steps to put the unit into storage:

1. Remove the twine from the unit.
2. Set the twine arm to approximately three feet from the knotter.
3. Move the red actuator arm to the up position.
4. Place the jack-stand in the weight bearing position.
5. Thoroughly wash the unit with a pressure washer or water hose to remove all loose hay, mud, dirt, and debris. Take care not to damage any of the safety stickers on the unit.
6. Follow the instructions in “11.3 Lubricating” on page 34 section to:
 - Grease all points.
 - Lubricate the chains.
 - Lubricate the Flow Control Valve Plunger.

NOTE: Be sure that all greasing and lubrication are done thoroughly so as to displace water and prevent the unit from seizing in the off-season.

7. Move the twine arm into the knotter.
8. Move the unit to the place selected for storage and place it on the ground.
9. Disconnect the hydraulic couplers and any wires. Refer to “6. Connecting Hoses to Machine” on page 17. Detach the unit from the machine. Place the hoses and any wires on top of the unit. Do not allow them to lie on the ground.

NOTE: If the unit is not being stored inside a building you may want to cover the unit to protect it from UV damage.

13.1.1 Removing from Storage

Perform all maintenance in the “12. Maintenance Service Schedule Sheet” on page 37 of this manual.

Attach the unit to the machine following the instructions in the “5. Tie Grabber Attachment” on page 16.

Refer to “8.2 Pre-Operation” on page 22 before placing your unit into operation.

NOTE: Make sure to re-familiarize yourself with the controls for the unit.

14. Troubleshooting

Problem	Cause	Solution	Instructions
Hooks are set into the bales before the squeeze arm closes completely	Sequence valve is improperly adjusted	Adjust the SV2 sequence valve	Adjust sequence valve in a CW direction. Adjustments should be no more than 1/4 turn at a time. Retest the operation between each adjustment.
			Check for proper adjustment. The initial setting should be 3 and 3/4 turns from a complete closed position.
			If adjustments do not affect the timing of the hooks to the squeeze arm, replace sequence valve.
Squeeze arm opens before hooks release	Sequence valve is improperly adjusted	Adjust the SV1 sequence valve	Adjust sequence valve in a CW direction. Adjustments should be no more than 1/4 turn at a time. Retest the operation between each adjustment.
			Check for proper adjustment. The initial setting should be 3 and 3/4 turns from a complete closed position.
Twine arm does not feed into the knotter and start knotter cycle	Valve is improperly adjusted	Adjust the RV valve	Adjusting the valve in a counter clock wise direction will slow down or stop the twine arm moving into the knotter. Adjusting the valve clock wise will speed up the movement of the twine arm into the knotter. Only adjust the valve 1/4 turn at a time. Test the speed between each adjustment.
Twine arm does not return or slowly returns to the retracted position.	Valve is improperly adjusted	Adjust the FC2 valve	Adjusting the valve in a counter clock wise direction will speed up the movement of the twine arm away from the knotter.
Twine arm returns to fast to retracted position.	Valve is improperly adjusted	Adjust the FC2 valve	Adjusting the valve in a clock wise will slow down or stop the twine arm moving away from the knotter. Only adjust the valve 1/4 turn at a time. Test the speed between each adjustment. NOTE: Adjusting the valve more than a quarter turn at a time can result in the arm moving very quickly.

Problem	Cause	Solution	Instructions
Twine arm makes a loud metallic sound when it contacts the stop	Twine arm bumper stop is missing	Replace the bumper	Place the replacement bumper on to the 1/4 bolt insert the bolt into the bumper mount hole
Twine end won't stay in the knotter	First: The needle is not set correctly in relationship to the twine holder	Reposition the needle	Follow the instructions in the "10.5 Needle Position Within the Knotter" on page 31 - Needle Position Setting.
	Second: Twine disk are out of alignment	Adjust the twine disk alignment	Follow the instructions in the "10.4 Twine Disc Assembly" on page 31.
	Third: Twine disks are jammed	Remove the twine fragments from the twine disks	
Twine ends of knot frayed or uneven	Knife blade is damaged or missing Twine Disc set too tight	Replace the knife blade	Remove the damaged or broken knife blade. Attach the new knife blade.

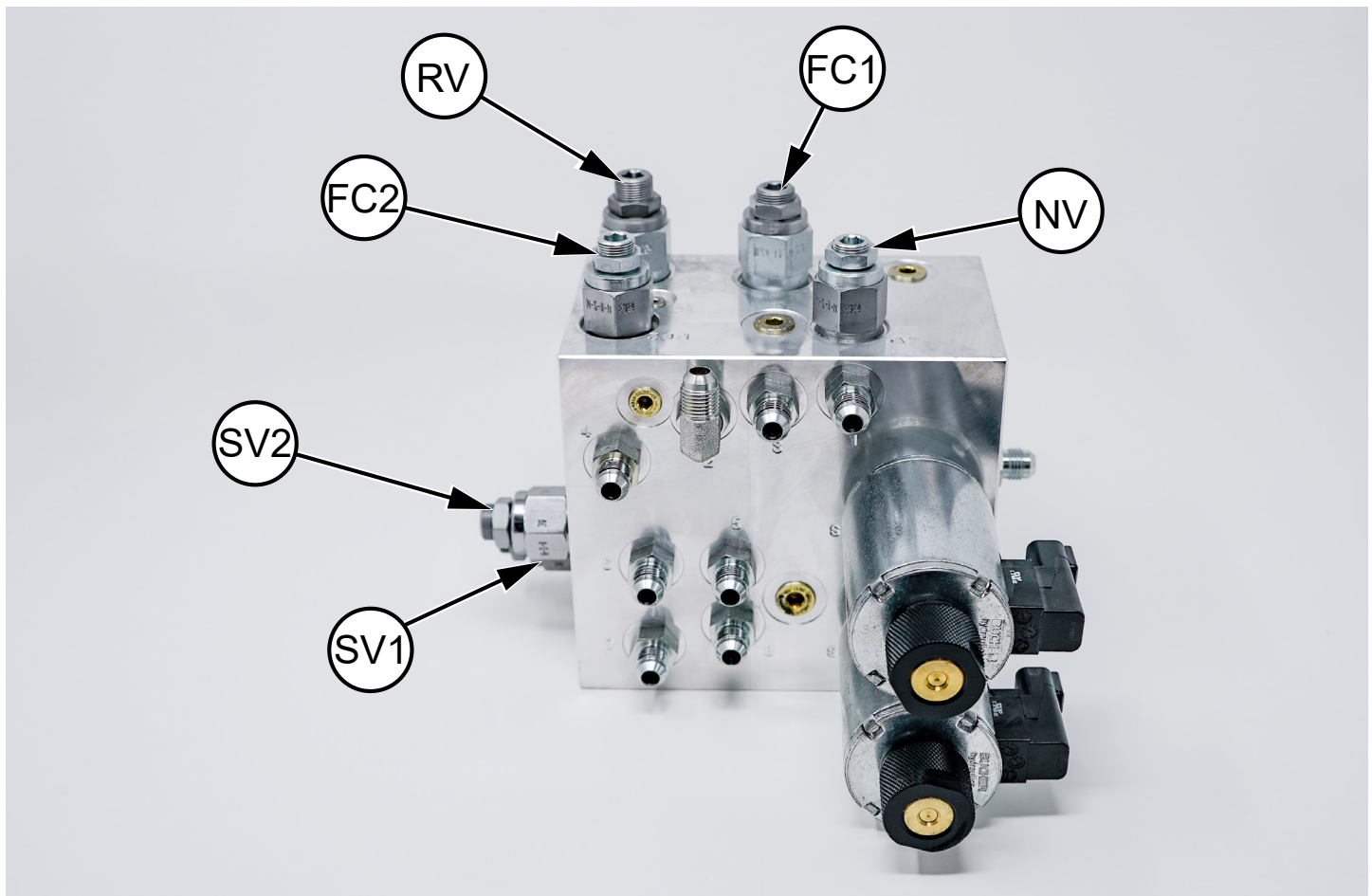

Problem	Cause	Solution	Instructions
Twine is frayed	Twine is being cut by a sharp edge	Trace the twine path and remove any sharp edges or burrs. Check the tip of the needle for any sharp edges or burrs.	Starting at the knotter follow the twine back along its path to the twine box looking for anything that the twine could catch on such as burrs, sharp edges, or cracks. If you should find any of these, they will need to be fixed or replaced.
Knotter does not rotate or turns too slowly to properly tie the knot	First: Plunger valve is sticking	Oil the plunger valve shaft	Using WD-40 lubricate the plunger valve shaft. Depress the valve a couple of times to work the oil into the shaft.
	Second: Valve is improperly adjusted	Adjust the NV valve	Adjusting the valve in a counter clock wise direction will speed up the knotter rotation. Adjusting the valve in a clock wise will slow down or stop the knotter rotation. Only adjust the valve 1/4 turn at a time. Test the speed between each adjustment. Refer to "8.4 Normal Knotter Operation" on page 24.
Knotter stalls mid-cycle.	Twine build up in Twine Disc	First: Clean out twine build up	Pull out any pieces of twine stuck in the twine disc.
	Not enough hydraulic pressure to the Knotter Motor	Second: Adjust RV valve	Adjust RV valve CW to increase the hydraulic pressure to the Knotter Motor.
One end of the twine has a knot and the other end has no knot	First: Twine is not being held properly with the tucker finger (not extending far enough onto the bill hook)	First: Check the tucker finger spring	Refer to "11.5 Springs" on page 36 to check that the tucker finger spring is unbroken and in place. If it is missing or damaged replace it.
		Second: Check the timing on the cam	Follow the instructions in the "10.6 Cam Timing Mark" on page 31.
		Third: Adjust the tucker finger linkage	Follow the instructions in the "10.7 Tucker Finger" on page 32.
	Second: Twine disk are out of alignment	Adjust the twine disk alignment	Follow the instructions in the "10.4 Twine Disc Assembly" on page 31.
	Third: Twine disks are jammed	Remove the twine from the twine disks	
Twine is breaking	Twine Tension is to high	Adjust the twine tensioner springs	Follow the instructions in the "10.10 Twine Tensioner" on page 32.

15. Parts

15.1 Main Tie Grabber Assembly

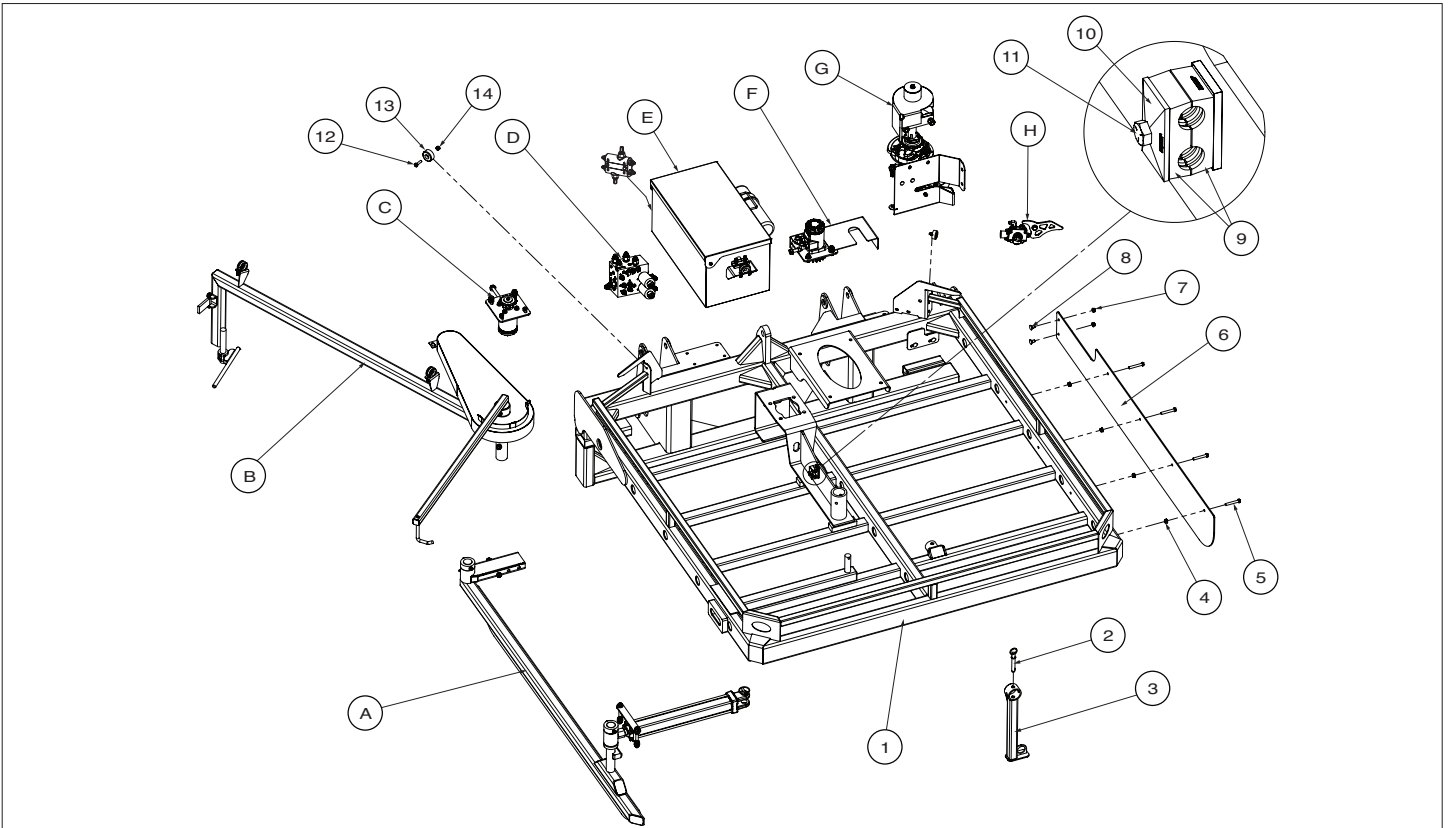

Item	Description	Manual Section
A	Squeeze Arm Assembly	15.3
B	Twine Arm Stack	15.4
C	Twine Arm Motor Group	15.5
D	Manifold Assembly	15.6
E	Twine Box Assembly Crossover Relief Valve	15.7
F	Knotter Motor Group	15.10
G	Knotter Main Assembly	15.9
H	Plunger Valve Assembly	15.8

Item	Part Number	Description	Qty
1		Tie-Grabber Frame	1
2	1005690	Jack Pin - 9/16"	1
3	1000370	Grabber Stand, Long	1
4	1006190	3/8" Serrated Flange Nut	3-5
5	1006860	3/8" x 2.5" Bolt Grade 5	3-5
6	1010500	Side Plate, KN408F	1
	1010511	Side Plate, KN510	
	1010521	Side Plate, KN510F	
	1010531	Side Plate, KN615	
	1010541	Side Plate, KN615L	
7	1006190	3/8" Serrated Flange Nut	2
8	1006300	3/8" x 3/4" Carriage Bolt Grade 5	2
9	1008800	3/8" Hose Clamp Body	4
10	1008810	3/8" Hose Clamp Cover Plate	2
11	1008790	5/16" x 1 3/8" Hex Bolt Grade 5	2
12	1007620	1/4" x 1" Bolt Grade 5	2
13	1003560	Rubber Bumper	2
14	1006070	1/4" Nylock Nut	2

15.2 Hooks

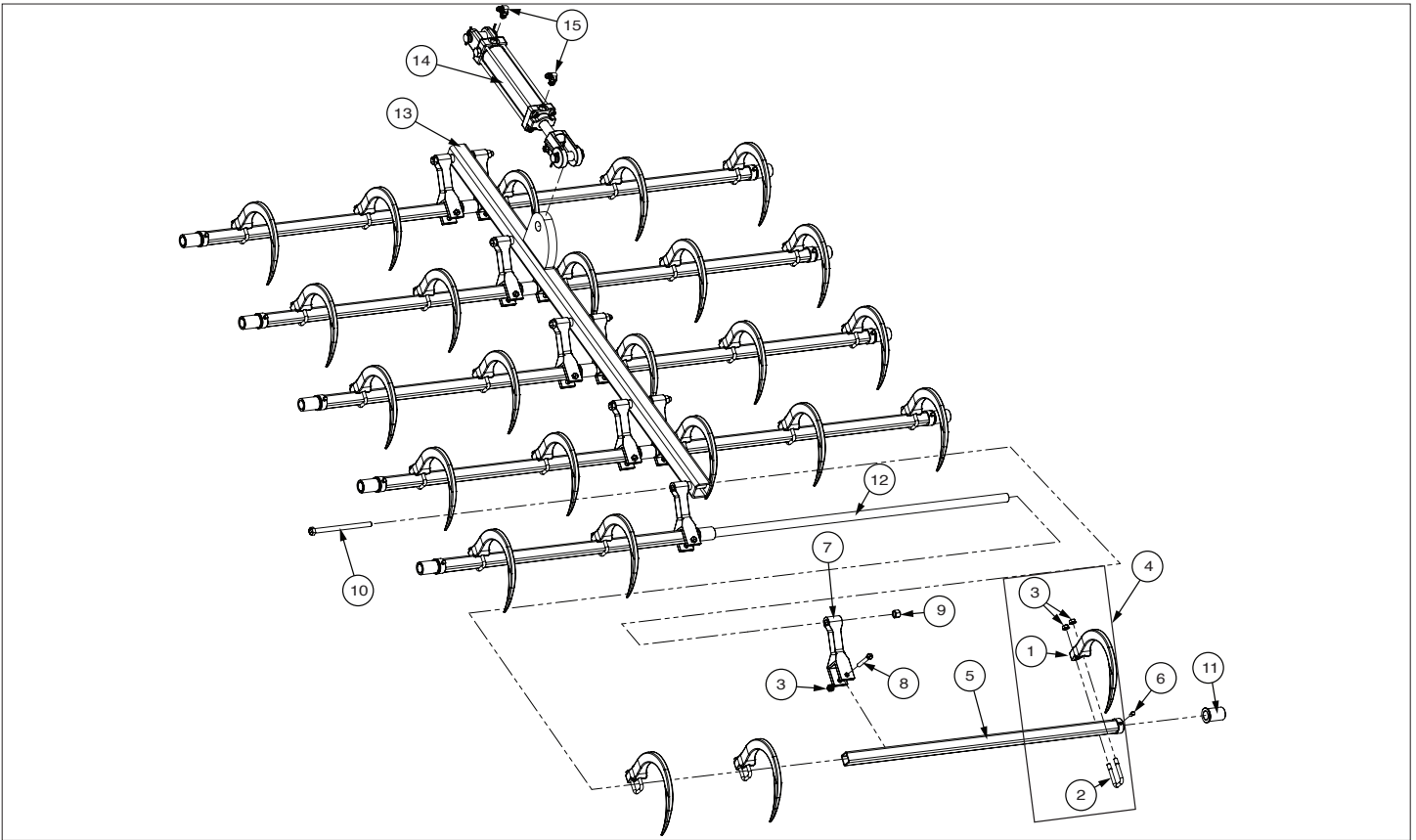

Item	Part Number	Description	Qty.
1	1005721	Bale Hook	16-36
2	1006881	Grabber Hook U-bolt	16-36
3	1006190	3/8" Serrated Flange Nut	40-84
4	1005450	Grabber Hook Tube, 31.5"	4-12
	1005460	Grabber Hook Tube, 33.5"	
	1005470	Grabber Hook Tube, 41"	
5	1006870	Square Head Set Bolt, 5/16"-18 X 1/2"	8-12
6	1005710	Actuator Arm	8-12
7	1006860	3-8 16 x 2.5 Hex Bolt Grade 5	8-12
8	1006110	1-2 13 Nylock Nut Grade 5	4-6
9	1006270	1-2 13 x 7 Hex Bolt Grade 5	4-6
10	1005700	UHMW Bushing	12-18
11	1005430	Grabber shaft, 71.75"	4-6
	1005440	Grabber shaft, 88 7/8"	
12	1005340	408F Center Bar	1
	1005350	510 Center Bar	
	1005360	510F Center Bar	
	1005370	615, 618 Center Bar	
	1005380	615L, 618L Center Bar	
13	1000360	2x8 ASAE Hydraulic Cylinder	1
14	1009690	3/8" 90° Hydraulic Fitting	2
15	1017460	Grabber Hook with U-bolt	16-36

15.3 Squeeze Arm Assembly

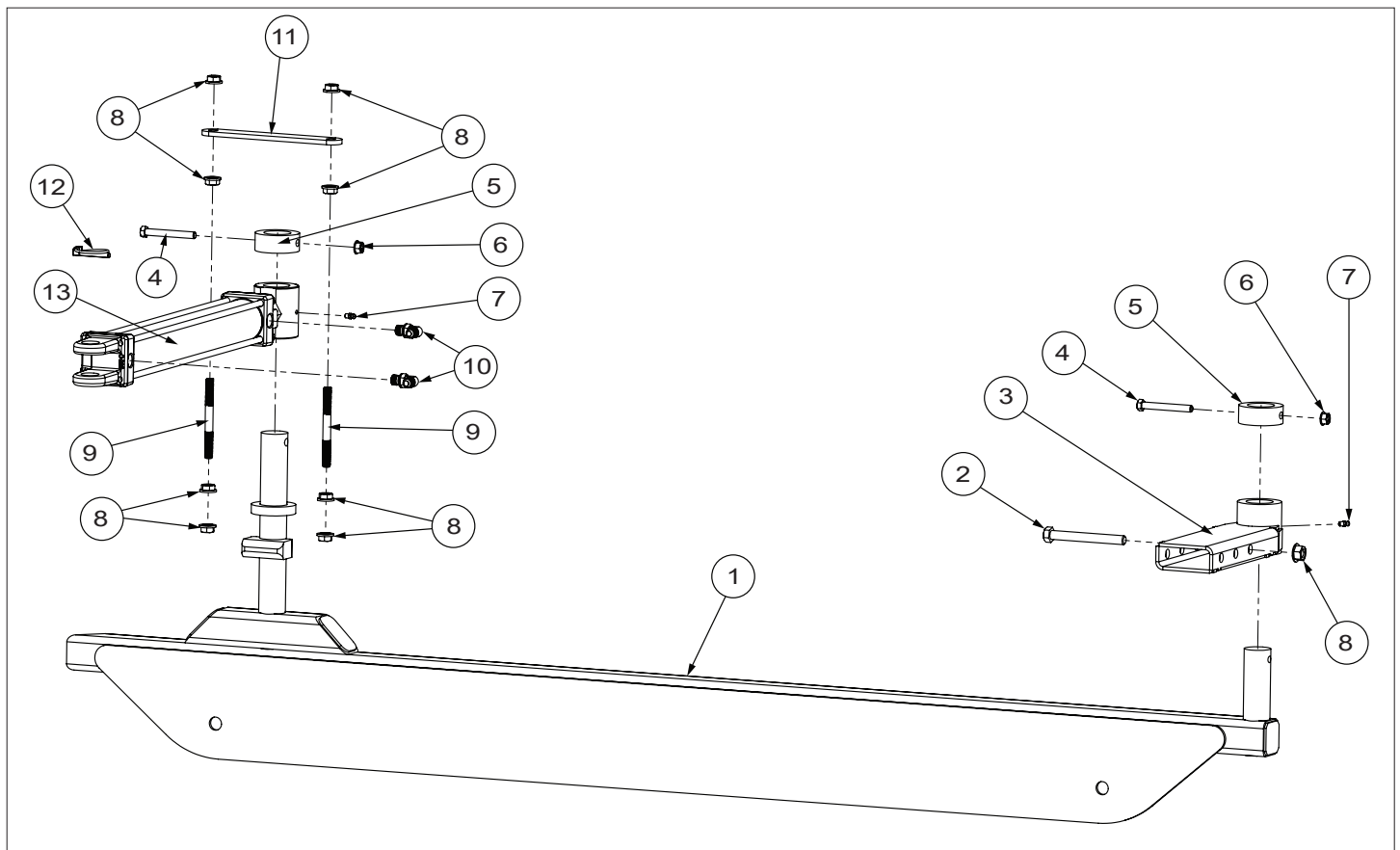

Item	Part Number	Description	Qty.
1	1010572	Squeeze Bar, KN408F KN510	1
	1010582	Squeeze Bar, KN510F	
	1010592	Squeeze Bar, KN615 KN618	
	1010602	Squeeze Bar, KN615L KN618L	
2	1006890	1/2" x 4.5" bolt Grade 5	1
3	1010551	Squeeze Bar Bracket, Tie Grabber	1
4	1006840	3/8" x 3" Bolt Grade 5	2
5	1005540	Squeeze Arm Collar	2
6	1006190	3/8" Serrated Flange Nut	2
7	1003730	Self Tapping Grease Zerk, 1/4"	2
8	1006210	1/2" Serrated Flange Nut	8
9	1008870	Cylinder Strap Bolt	2
10	1009690	6MJ-6MB90 Adapter	2
11	1008861	Cylinder Anchor Plate	1
12	1006850	5/16" Lynch pin	1
13	1006820	2x16 Hydraulic Cylinder	1

15.4 Twine Arm Stack

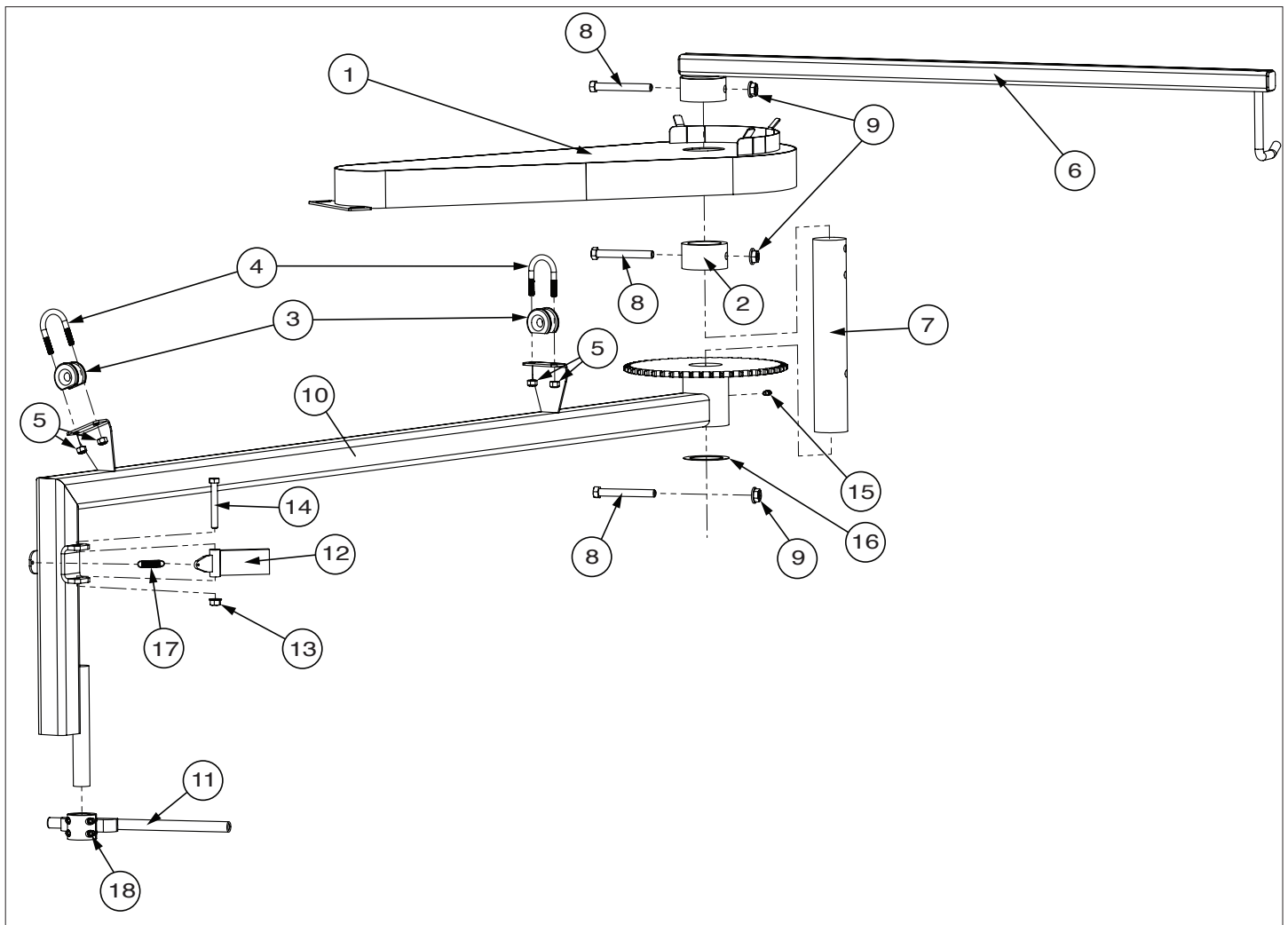

Item	Part Number	Description	Qty
1	1011680	Twine Arm Chain Shield, 16.5 KN408F, KN612F, KN615, KN615L, KN615F, KN618	1
	1011690	Twine Arm Chain Shield, 19.75 KN618L	
	1011700	Twine Arm Chain Shield, 22.25 KN510, KN510F	
*	1020000	Twine Arm Chain for KN408F, KN612F, KN615, KN615L, KN615F, KN618	1
	1020010	Twine Arm Chain for KN618L	
	1020020	Twine Arm Chain for KN510, KN510F	
2	1010620	Twine Arm Collar	1
3	1008930	Ceramic Insulator	2
4	1009400	U-bolt, 5/16"-18 1-3/8" ID	2
5	1006080	5/16 Nylock Nut	4
6	1012750	Twine Catcher, 38"	1
7	1008780	Twine Arm Shaft	1

Item	Part Number	Description	Qty
8	1007430	7/16" x 3.5" bolt Grade 5	3
9	1006200	7/16" serrated flange nut	3
10	1008460	Twine Arm, KN408F KN510	1
	1008470	Twine Arm, KN510F	
	1008480	Twine Arm, KN612F KN615	
	1008490	Twine Arm, KN615F KN618	
	1008500	Twine Arm, KN615L	
	1008510	Twine Arm, KN618L	
11	1010491	Twine Arm needle	1
12	1008940	Twine Arm Knotter Stop	1
13	1006190	3/8" serrated flange nut	1
14	1006370	3/8" x 2.75" bolt Grade 5	1
15	1003730	Self Tapping Grease Zerk, 1/4"	1
16	1013800	2.75x2x0.060 Shim	1-2
17	1010940	Knotter Stop Spring	1
18	1016500	1/4-28 X 5/8 Zinc Plated Socket Head Cap Screw	4

* Parts not shown in diagram

15.5 Twine Arm Motor Group

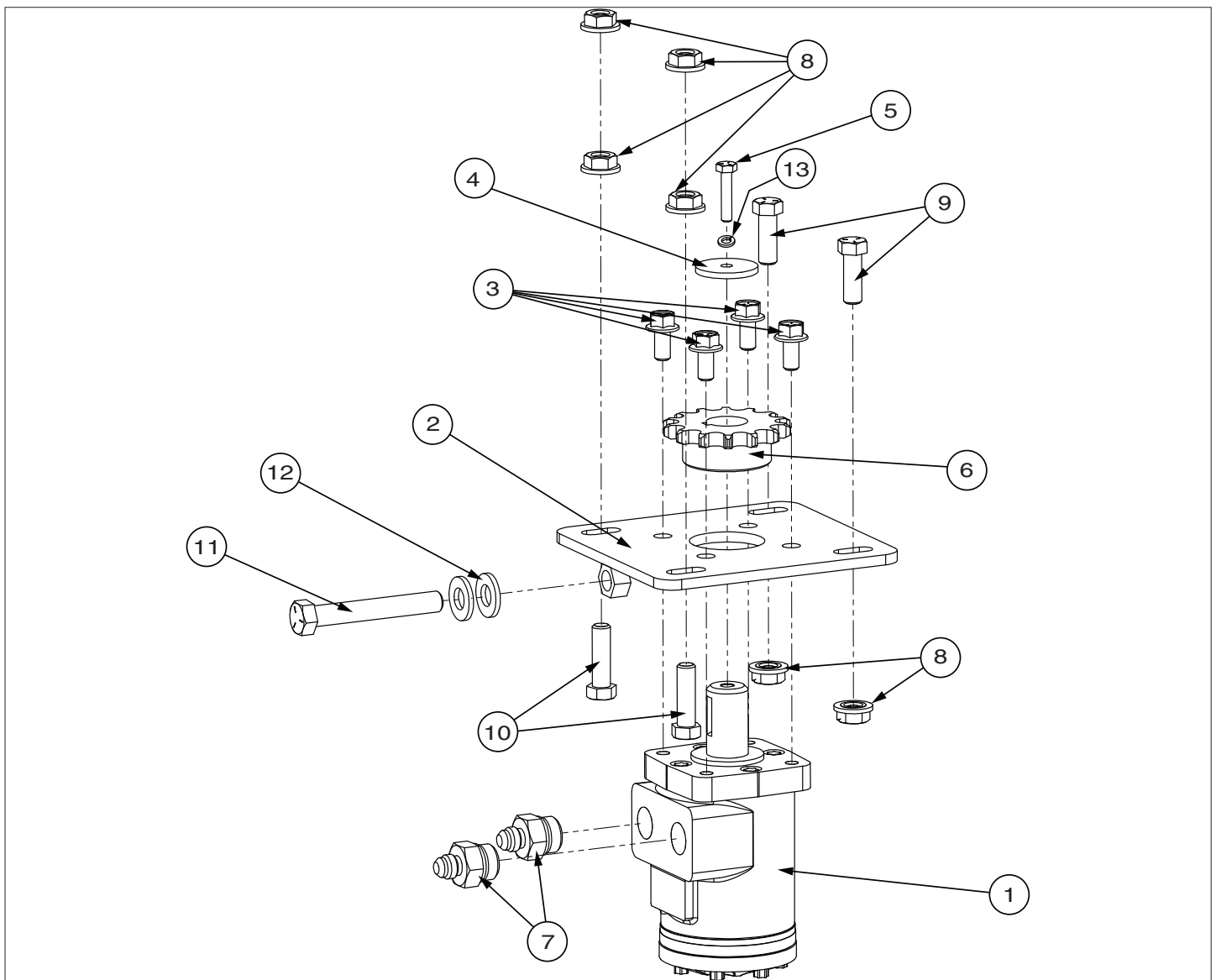

Item	Part Number	Description	Qty
1	1016420	Hydraulic Motor	1
2	1010480	Motor Mounting Plate	1
3	1006330	3/8 16 x 0.75 Serrated Flange Bolt	4
4	1010300	1-4" x 1.5" Fender Washer	1
5	1007630	1-4 20 x 1.25 Hex Bolt Grade 5	1
*	1009730	1/4" Split Lock Washer	1
6	1016320	Small Sprocket For HYD Motor	1
7	1016610	6MJ-10MB Straight Adapter	2
8	1006200	7/16"-14 Serrated Flange Nut Grade 5	6
9	1007270	7/16"-14 x 1.25" Hex Bolt Grade 5	2
10	1010310	7/16" x 1.5" Grade 5 Bolt	2
11	1007460	1/2-13" x 3.5 Hex Bolt Grade 5	1
12	1006170	1/2" Washer	4
13	1009730	Split Lock Washer 1/4"	1

15.6 Manifold Assembly

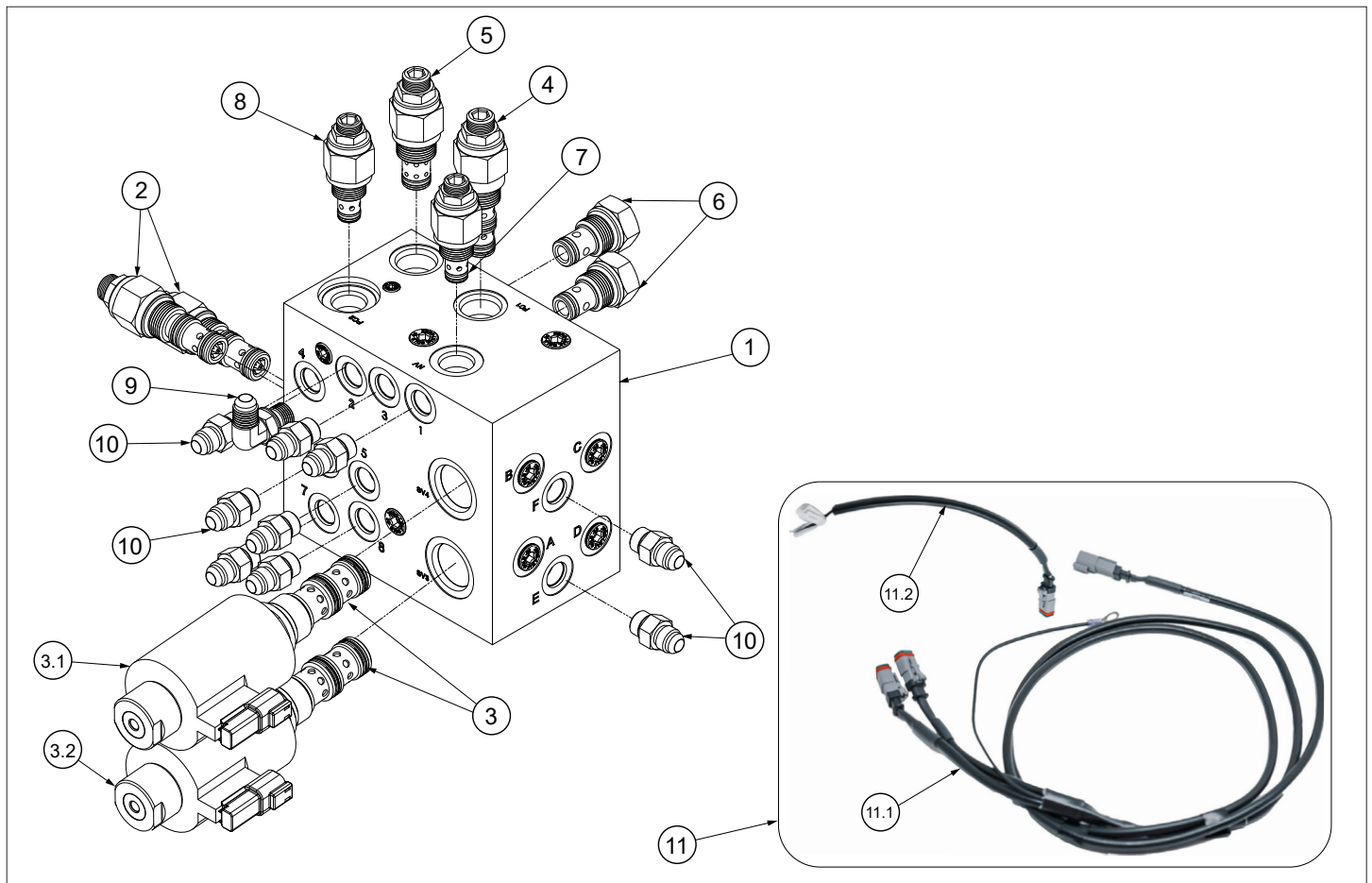

Item	Part Number	Description	Qty
1	1009610	Manifold Block with ports	1
2	1009010	Sequence Valve PSVP-10	2
3	1034280	Splitter Solenoid, Bucher ESDV-12	2
3.1	1035860	Coil Body, ESDV Solenoids	
3.2	1035870	Coil Nut	
4	1009650	Back Flow Control Valve BFCV-10	1
5	1009660	Relief Valve RVBD-10	1
6	1009670	Check Valve CVFB-10	2
7	1009630	Flow Control Valve, Needle Valve	1
8	1009640	Flow Control Valve, Free Flow Check	1
9	1009690	6MJ-6MB90 Adapter	1
10	1009680	6MJ-6MB Straight Adapter	9
11	1034430	Wire Harness, 2-Pin Tie-Grabber Solenoids	1
11.1	1034290	Wire Assembly, Tie-Grabber Solenoids	1
11.2	1034420	Wire Assembly, 12" Pigtail	1

15.7 Twine Box Assembly, Crossover Relief Valve

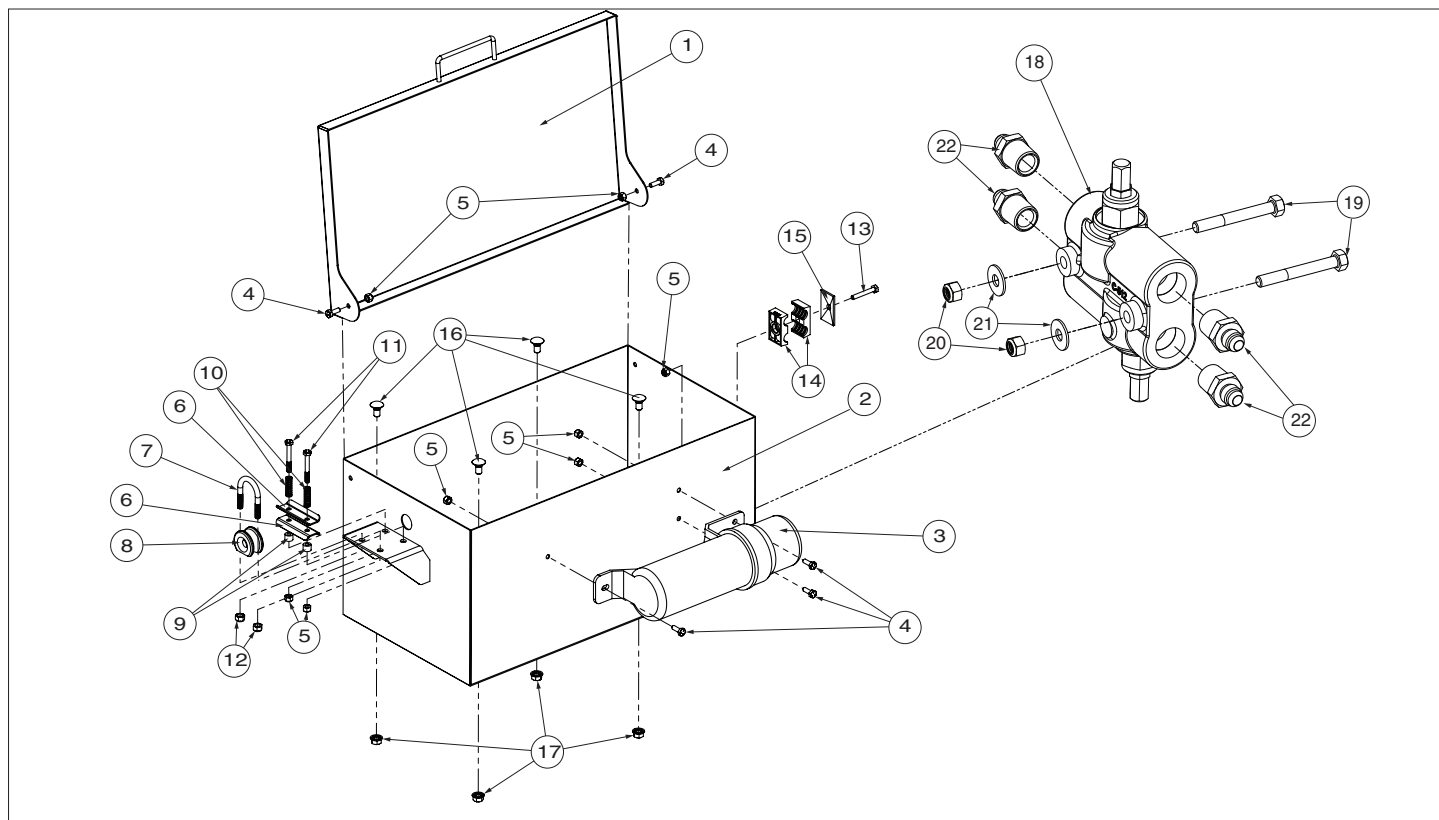

Item	Part Number	Description	Qty
1	1011650	Twine Box Lid	1
2	1011600	Twine Box	1
3	1006430	Owner's Manual Tube	1
4	1006420	1-4 20 x 0.75 Hex Bolt Grade 5	5
5	1006070	1-4 20 Nylock Nut Grade 5	8
6	1010270	Twine Tensioner Plate	2
7	1009400	U-bolt, 5/16"-18 1-3/8" ID	1
8	1008930	Ceramic Insulator	1
9	1010330	Nylon Spacer	2
10	1010340	Twine Box Tensioner Spring	2
11	1010320	1-4 x 2" Hex Bolt Grade 5	2
12	1006080	5-16 18 Nylock Nut Grade 5	2
13	1007640	1-4 20 x 1.75 Hex Bolt Grade 5	1
14	1008800	3/8" Hose Clamp Body	2
15	1008810	3/8" Hose Clamp Cover Plate	1
16	1006300	3-8 16 x 0.75 Carriage Bolt Grade 5	4
17	1006190	3/8" Serrated Flange Nut	4
18	1024540	Crossover Relief Valve 1500-3000psi	1
19	1025810	5/16" x 2.5" Hex Bolt (Grade 5)	2
20	1006080	5/16 Nylock Nut	2
21	1006150	3/8" Washer	2
22	1024550	6MJ-8MP Adapter	4

15.8 Plunger Valve Assembly

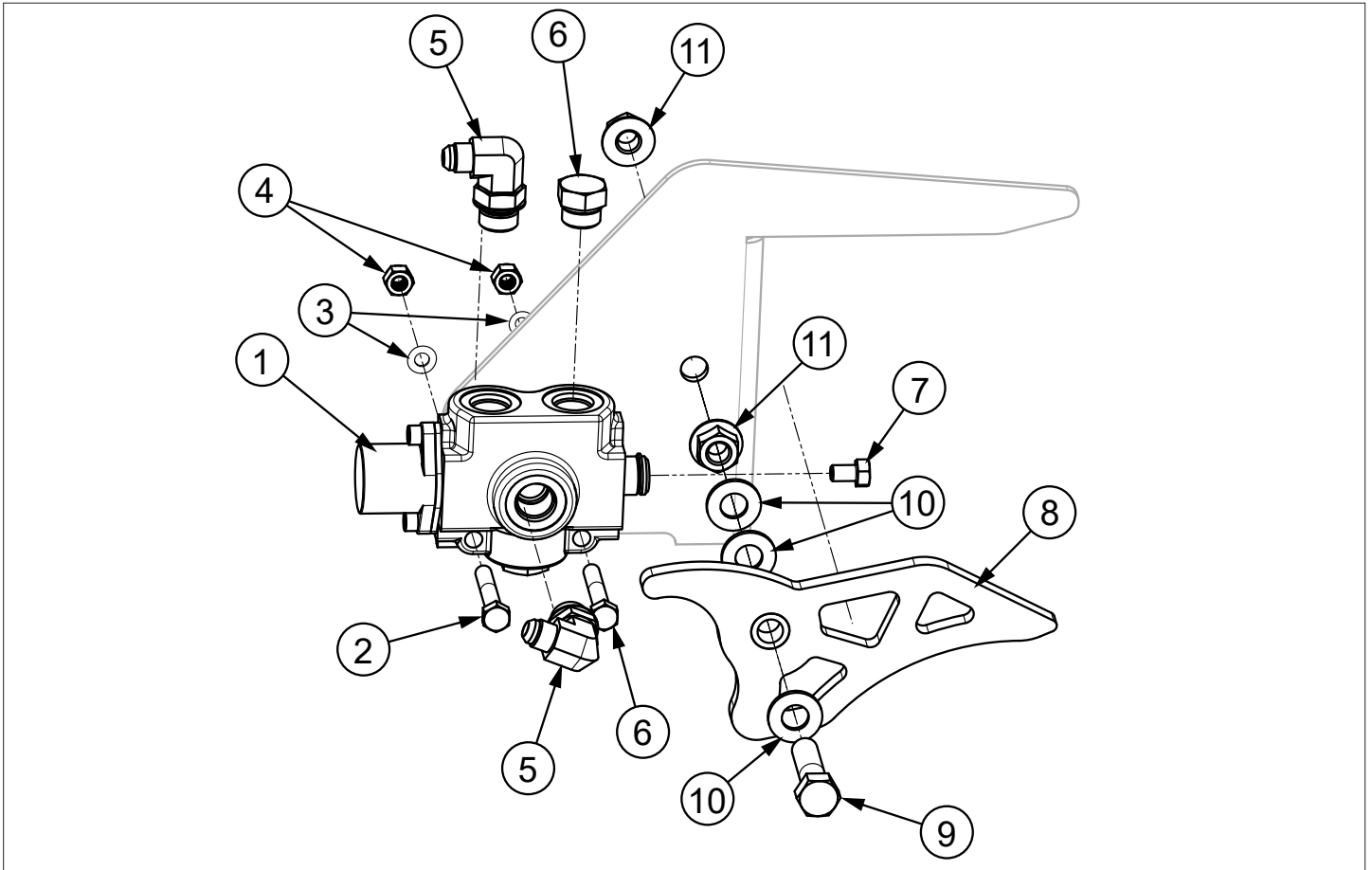

Item	Part Number	Description	Qty
1	1016280	Plunger Valve Regular	1
2	1007400	5-16 18 x 2 Hex Bolt Grade 5	2
3	1006140	5-16" Washer	2
4	1006080	5/16 Nylock Nut	2
5	1017270	6MJ-8MB90 Adapter	2
6	1016300	8MB Plug	1
7	1036060	5/16"-18 x 0.5 Hex Bolt with Nylon Patch	1
8	1035920	Plunger Valve Actuator with Bushing	1
9	1007320	1/2-13 x 2 Hex Bolt Grade 5	1
10	1006170	1/2" Washer	3
11	1006210	1/2-13 Serrated Flange Nut Grade 5	2

15.9 Knotter Main Assembly

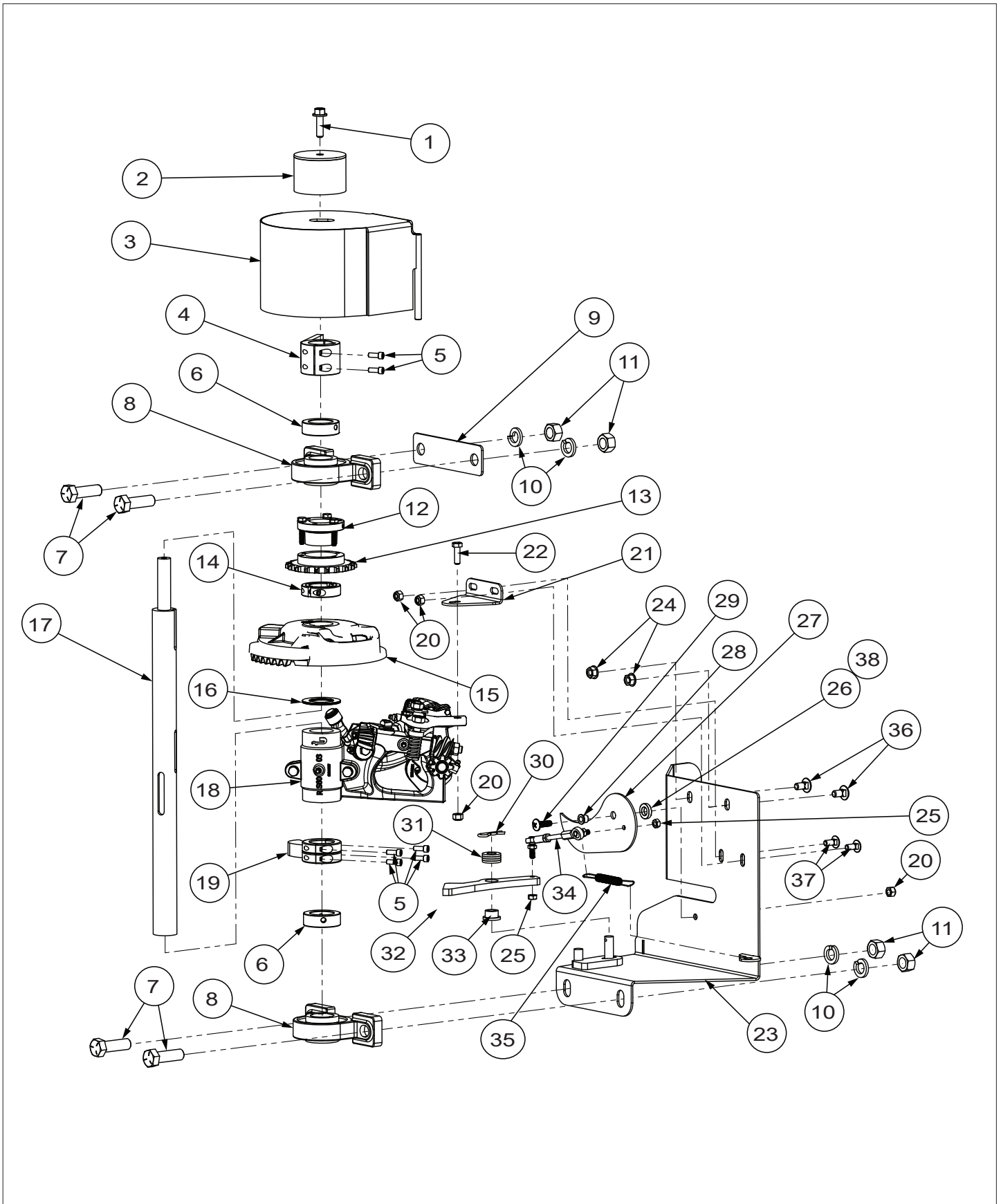

Item	Part Number	Description	Qty
1	1007390	3/8" x 1.25" Serrated Flange Bolt Grade 5	1
2	1010460	Knotter Indicator	1
3	1010470	Knotter Stop Shield	1
4	1008980	Shaft Mounted Knotter Stop	1
5	1016500	1/4-28 X 5/8 Zinc Plated Socket Head Cap Screw	6
6	1017520	Bearing Locking Collar for 1.375" Bearing	2
7	1007330	5/8" x 2" Bolt Grade 5	4
8	1017510	Knotter Bearing - 1.375"	2
9	1015870	Knotter Pocket Spacer	1
10	1010790	5/8" Lock Washer	4
11	1010800	5/8" Hex Nut	4
12	1016350	Taper Bushings	1
13	1016360	Knotter Sprocket	1
14	1012260	1.375 Double Split Collar	1
15	1017180	Knotter Hub	1
16	1017170	Knotter Shim	5-9
17	1008690	Knotter Shaft	1
18	1017190	Knotter Frame Assembly	1
19	1010290	Rocker Arm Cam	1
20	1006080	5/16 Nylock Nut	1
21	1010440	Knotter Holder	1
22	1006290	5/16" x 1" Bolt Grade 5	1
23	1010450	Knotter Pocket	1
24	1006190	3/8" Serrated Flange Nut	2
25	1010780	1/4" 28 Hex Nut	2
26	1016380	Tucker Finger Spacer	1
27	1010610	Tucker Finger	1
28	1010750	Tucker Finger Bushing	1
29	1010720	5/16" x 1" Phillips Head bolt	1
30	1008280	1/8" x 1 7/8" Cotter Pin	1
31	1006170	1/2" Washer	3-6
32	1012671	Rocker Arm	1
33	1016230	Actuator Bushing	1
34	1015210	Tucker Finger Linkage (2- Ball joint ends 1- Threaded rod 1/4" 1- 1/4"-28 Nut)	1
35	1010770	Tucker Finger Spring	1
36	1006300	3/8" x 3/4" Carriage Bolt Grade 5	2
37	1010880	5/16" x 0.75" Carriage Bolt Grade 5	2
38	1016380	5/16" Washer	1

15.10 Knotter Motor Group

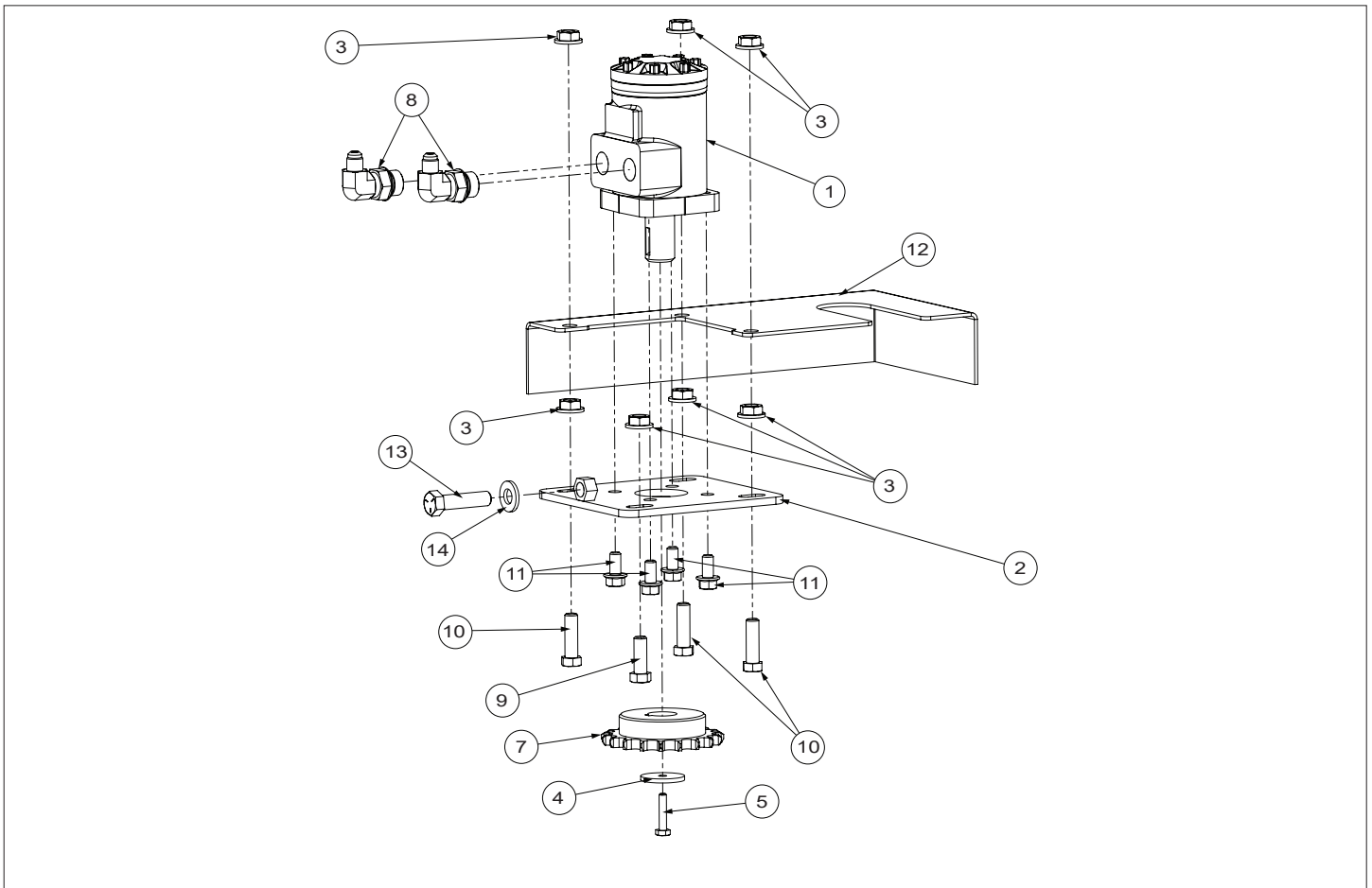

Item	Part Number	Description	Qty
1	1016420	Hydraulic Motor	1
2	1010480	Motor Mounting Plate	1
3	1006200	7/16"-14 Serrated Flange Nut Grade 5	7
4	1010300	1-4" x 1.5" Fender Washer	1
5	1007630	1-4 20 x 1.25 Hex Bolt Grade 5	1
*	1009730	1/4" Split Lock Washer	1
7	1016620	Large Sprocket For HYD Motor	1
8	1016290	6MJ-10MB90 Adapter	2
9	1007270	7/16"-14 x 1.25" Hex Bolt Grade 5	1
10	1010310	7/16" x 1.5" Grade 5 Bolt	3
11	1006330	3/8 16 x 0.75 Serrated Flange Bolt	4
12	1010420	Knotter Chain Shield, Narrow	1
	1010430	Knotter Chain Shield, Wide	
*	1020030	Chain for Knotter, Narrow	1
	1020040	Chain for Knotter, Wide	
13	1007320	1-2 13 x 2 Hex Bolt Grade 5	1
14	1006170	1/2" Washer	4

* Parts not shown in diagram



Norden Mfg LLC
4210 Kinsman Road NW
North Bloomfield, OH 44450

(877) 296-5851

www.nordenmfg.com
support@nordenmfg.com

Norden Mfg is the successor to Kuhns Mfg  and all liability and warranty claims are transferable.

1008421 Rev. B
Revised 12-2024